

# CHEMISTRY DIAPHRAGM PUMPS WITH ATEX CONFORMITY

*MZ 2C EX*

*MD 4C EX*

*MV 10C EX*

*MZ 2C EX + AK + EK*

*MD 4C EX + AK + EK*

*MV 10C EX + AK + EK*

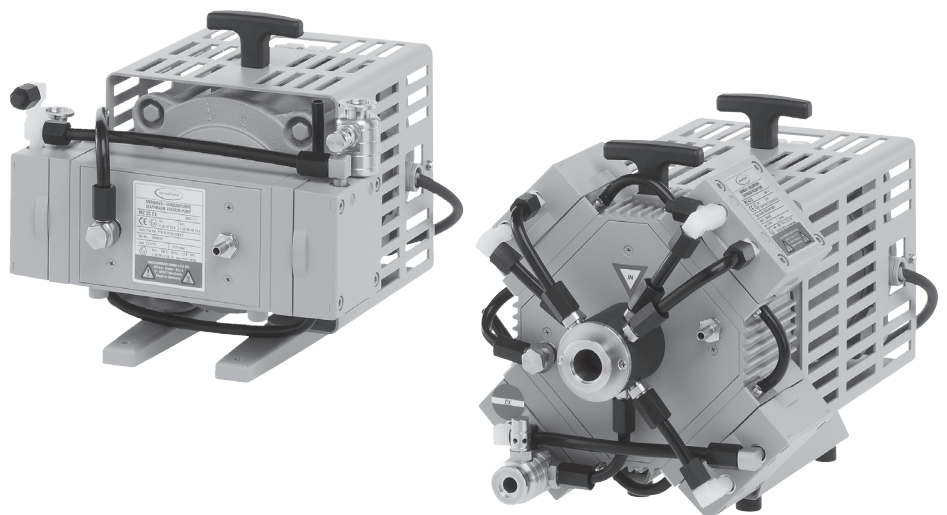

## Instructions for use



Dear customer,

Your VACUUBRAND diaphragm pump shall support you at your work for a long time without any trouble and with full load output. Thanks to our large practical experience we attained much information how you could add to an efficient application and to personal safety. Please read these instructions for use prior to the initial start-up of your pump.

VACUUBRAND diaphragm pumps are the result of many years of experience in construction and practical operation of these pumps combined with the latest results in material and manufacturing technology.

Our quality maxim is the "zero fault principle":

Every delivered diaphragm pump is tested extensively including an endurance run of 14 hours. Due to this endurance run, also faults, which occur rarely, are reported and can be corrected. Every single diaphragm pump is tested on achievement of the specification after the endurance run.

**Every VACUUBRAND pump leaving our factory achieves the specification. We feel obliged to this high quality standard.**

We are aware that the vacuum pump should not draw a part of the real work and we hope to contribute with our products to an effective and trouble-free realisation of your work.

Yours

VACUUBRAND GMBH + CO KG

**After sales service: Contact your local dealer or call +49 9342 808-5500.**



**Attention: The manual of the offered device with ATEX approval is available in German, English and French (DVR 3: also Dutch). The user is only permitted to operate the device if he understands one of these languages or a technically correct translation of the complete manual. The manual must be completely read and understood before operation of the device. All specified measures must be applied, or else must be replaced by equivalent measures at the user's own risk.**

**The device has an ATEX approval according to EC-directives and standards. Users outside of the European Community must check national regulations for hazardous areas.**

**Trademark index:**

VACUU-LAN® (US-Reg.No 3,704,401), VACUU-BUS®, VACUU-CONTROL®, VACUU-SELECT® (US-Reg.No 5,522,260), VARIO® (US-Reg.No 3,833,788), VACUUBRAND® (US-Reg.No 3,733,388), VACUU-VIEW®, GREEN VAC® (US-Reg.No. 4,924,553), VACUU-PURE® (US-Reg No. 5,559,614) and also the shown company logos are registered trademarks of VACUUBRAND GMBH + CO KG in Germany and/or other countries.

**D, A, CH, B, L**

Achtung: Die Betriebsanleitung des angebotenen Geräts mit ATEX-Zulassung ist in Deutsch, Englisch und Französisch (DVR 3: auch Niederländisch) verfügbar. Der Anwender darf das Gerät nur dann in Betrieb nehmen, wenn er eine dieser Sprachen oder eine fachlich korrekte Übersetzung der vollständigen Anleitung versteht. Die Betriebsanleitung muss vor Inbetriebnahme des Geräts vollständig gelesen und verstanden werden, und alle geforderten Maßnahmen müssen eingehalten werden. Das Gerät verfügt über eine ATEX-Zulassung gemäß EU-Richtlinien und Normen. Anwender außerhalb der EU müssen die nationalen EX-Vorschriften prüfen.

**GB, IRL**

Attention: The manual of the offered device with ATEX approval is available in German, English and French (DVR 3: also Dutch). The user is only permitted to operate the device if he understands one of these languages or a technically correct translation of the complete manual. The manual must be completely read and understood before operation of the device and all required measures must be applied. The device has an ATEX approval according to EC-directives and standards. Users outside of the European Community must check national regulations for hazardous areas.

**F, B, L**

Attention : le manuel d'utilisation de l'appareil ATEX proposé est disponible en allemand, anglais et français (en néerlandais également pour le DVR 3). L'utilisateur est autorisé à utiliser l'appareil uniquement s'il comprend l'une de ces langues ou une traduction techniquement correcte du manuel complet. Le manuel doit être lu et compris entièrement avant l'utilisation de l'appareil et toutes les mesures requises doivent être appliquées. L'appareil a une certification ATEX suivant les directives CE et les standards. Les utilisateurs en dehors de la communauté européenne doivent vérifier les normes locales pour les zones dangereuses.

**BG**

Внимание: Ръководството за работа с предлаганото устройство, което е с ATEX одобрение е достъпно на следните езици: немски, английски и френски език (DVR 3: също холандски). Потребителят има право да работи с устройството само ако разбира много добре един от тези езици или ползва технически правилен превод на пълното ръководство. Ръководството трябва да бъде изцяло прочетено и разбрано преди да се пристъпи към работа с устройството, а всички необходими мерки трябва да бъдат спазвани. Устройството има ATEX одобрение съгласно ЕС - директивите и стандартите. Потребители извън Европейската общност трябва да се съобразят със съответните национални разпоредби за опасни зони.

**CN**

注意：所提供的ATEX批准设备的操作说明书有德文版、英文版和法文版（DVR 3也有荷兰语版）。客户仅允许懂得其中一种语言或者整本说明书的正确技术翻译的情况下，才可以操作该设备。该说明书在操作前必须完全阅读且能够理解，所有需要的测试必须采用。该装置根据EC指令和标准有ATEX批准。欧盟以外区域的客户必须核查各自国家针对危险区域的国家标准。

## CZ



Pozor: Příručka pro nabízené zařízení s osvědčením ATEX je k dispozici v němčině, angličtině a francouzštině (DVR 3: i v holandštině). Uživatel smí dané zařízení používat pouze, pokud zná jeden z těchto jazyků nebo má k dispozici technicky správný překlad kompletního manuálu. Příručku musí kompletně přečíst a porozumět jí před zahájením provozu zařízení a musí zajistit uplatnění všech požadovaných opatření.

Přístroj má schválení ATEX podle směrnic a norem EU. Uživatelé mimo území Evropského společenství, musí ověřit vnitrostátní předpisy pro prostředí s nebezpečím výbuchu.

## DK



Bemærk: Betjeningsvejledningen til enheden "med ATEX-godkendelse" er til rådighed på Tysk, Engelsk og Fransk (DVR 3: også på Hollandsk)

Brugeren har kun tilladelse til at betjene enheden hvis, han/hun forstår et af de disse sprog eller har en teknisk korrekt oversættelse af hele manualen.

Betjeningsvejledningen skal læses og forstås før enheden kan anvendes og betjenes. Alle de krævede foranstaltninger skal overholdes.

Enheden har en ATEX godkendt certificering ifølge EF- direktiver og standarder.

Brugere uden for Det Europæiske Fællesskab skal kontrollere nationale regler for anvendelse.

## EE



Tähelepanu: käsiraamat pakutud ATEX-i poolt heakskiidetud seadmele on saadaval saksa, inglise ja prantsuse keeles (DVR 3: puhul ka Hollandi keeles). Kasutajal on lubatud seda seadet kasutada ainult juhul, kui ta saab aru ühest nendest keeltest või on olemas tehniliselt korrektnete tõlge kogu juhendist. Juhend peab olema täielikult loetud ja mõistetud enne seadmega töötamist ning kõiki vajalike meetmeid tuleb rakendada. Seadmel on ATEX-i heakskiit vastavalt EÜ-direktiividele ja standarditele. Kasutajad väljaspool Euroopa Liitu peavad kontrollima riiklikuid regulatsioone ohtlike piirkondade kohta.

## ES



Atención: Las instrucciones de funcionamiento del equipo ofrecido con homologación ATEX están disponibles en Alemán, Inglés y Francés (DVR 3: también en holandés). El usuario deberá poner en funcionamiento el equipo únicamente si comprende uno de estos idiomas o una correcta traducción técnica del manual completo en el idioma que comprenda. Las instrucciones deben ser leídas y entendidas antes de utilizar el equipo y deben cumplirse todas las medidas necesarias. El equipo posee una aprobación de conformidad ATEX con las directivas y normas de la UE. Los usuarios fuera de la UE deben verificar las normativas nacionales de protección contra explosiones.

## FI



Huomio! Tuotteen käyttöohje, joka sisältää ATEX -todistuksen, on saatavilla saksaksi, englanniksi ja ranskaksi (DVR 3 myös hollanniksi). Laitetta saa käyttää vain henkilö, joka ymmärtää jotain em. kielistä tai hänellä on teknisesti tarkka käänös alkuperäisestä käyttöohjeesta. Käyttäjän tulee lukea ja ymmärtää käyttöohje kokonaisuudessaan sekä noudattaa siinä mainittuja toimenpiteitä ennen laitteen käyttöä.

Tuotteella on ATEX hyväksyntä EU-direktiivien ja standardien mukaisesti. Jos laitetta käytetään EU:n ulkopuolella, tulee noudattaa paikallisia määräyksiä.

## GR



Προσοχή: Το εγχειρίδιο του προσφερόμενου οργάνου με πιστοποίηση ATEX είναι διαθέσιμο στα Γερμανικά, Αγγλικά, Γαλλικά ( DVR3: επίσης Ολλανδικά ). Ο χρήστης μπορεί να λειτουργεί το μηχάνημα εφόσον καταλαβαίνει μία από τις συγκεκριμένες γλώσσες ή μία τεχνικά σωστή μετάφραση του πλήρους εγχειριδίου. Το εγχειρίδιο θα πρέπει να αναγνωσθεί πλήρως και να γίνει κατανοητό πριν την λειτουργία του μηχανήματος και θα πρέπει να εφαρμόζονται όλα τα απαιτούμενα μέτρα. Το όργανο έχει πιστοποίηση ATEX σύμφωνα με τις οδηγίες και τα στάνταρ της Ευρωπαϊκής Ένωσης (E.E.). Χρήστες εκτός E.E. πρέπει να ελέγξουν τους εθνικούς τους κανονισμούς για τις τοποθεσίες επικινδυνότητας.

## HR



Pažnja: Upute o rukovanju ponuđenih uređaja sa ATEX odobrenjem su dostupne na njemačkom, engleskom i francuskom jeziku (DVR 3: također i na holandskom). Korisniku je dopušteno rukovanje uređajem ako razumije jedan od ovih jezika ili ako ima prijevod tehničke dokumentacije. Uputa za rukovanje prije korištenja uređaja mora se pročitati, razumjeti te je potrebno primijeniti sve nužne mjere za ispravno rukovanje. Uređaji imaju ATEX odobrenje prema smjernicama Europske unije i važećim standardima. Korisnici izvan Europske unije moraju provjeriti nacionalnu regulativu vezanu uz rad sa potencijalno opasnim supstancama te uređajima koji se koriste u tom potencijalno opasnom području rada.

## HU



Figyelem: a megajánlott ATEX minősítéssel rendelkező készülék kézikönyve németül, angolul és franciául érhető el (a DVR 3 hollandul is). Kérjük, csak akkor használja a berendezést, ha tökéletesen ért ezeken a nyelveken, vagy rendelkezésére áll egy technikailag megfelelő fordítás a teljes kézikönyvről. A kézikönyvet a készülék használatba vétele előtt kérjük végigolvasni, és betartani a benne foglaltakat. A készülék az EC-irányelveknek és előírásoknak megfelelő ATEX minősítéssel rendelkezik. Az Európai Közösségen kívüli vásárlók ellenőrizzék az adott országban érvényes veszélyes helyiségekre vonatkozó előírásokat.

## IT



Attenzione: il manuale della strumentazione con certificazione ATEX offerta è disponibile in Tedesco, Inglese e Francese. (DVR 3: anche in Olandese). L'utilizzatore può utilizzare l'apparecchiatura solo se capisce una di queste tre lingue o una traduzione tecnicamente corretta dell'intero manuale. Prima di utilizzare l'apparecchiatura il manuale deve essere completamente letto e tutte le indicazioni devono essere seguite. La strumentazione ha un'approvazione ATEX in conformità agli standards ed alle direttive EC. Al di fuori della Comunità Europea gli utilizzatori devono controllare la regolamentazione nazionale per le aree pericolose.

## JP



注意：ATEX認証された製品に付きましては、ドイツ語、英語、フランス語（DVR 3はオランダ語も）の取扱説明書がございます。ユーザーはこれらの言語が理解できるか、技術的に正しい完全なマニュアルがある場合のみ、装置を作動することが許されます。製品使用前にマニュアルは全て読み、理解しなければなりません。また、全ての要求される対策を講じなければなりません。この製品はECの指令及び規格により承認されています。EC外のユーザーに付きましては、自国の危険場所に関する規定をご確認ください。

## KR



주의 : ATEX 인증을 받은 본 장비의 매뉴얼은 독어, 영어, 불어 (DVR3 는 네덜란드어도 포함) 로 되어있습니다. 이들 언어중 하나를 독해 가능하거나 혹은 이 매뉴얼을 기술적으로 완벽하게 이해한 사용자만이 이 장비를 구동해야 합니다. 장비를 구동하기 전에 매뉴얼을 모두 읽고 이해하여야 하며, 모든 필수 요건들을 지켜야합니다. 장비는 ATEX 인증을 받았으며 이 인증은 EC의 지침과 규격에 따른 것입니다. 유럽공동체 이외 지역의 사용자들은 반드시 방폭에 대한 국가규정을 확인해야 합니다.

## LT



Dėmesio: Pasiūlyto prietaiso vartotojo instrukcija yra patvirtinta ATEX ir galima vokiečių, anglų bei prancūzų kalbomis (DVR3: taip pat olandų kalba). Teisę dirbti su prietaisu turi tik vartotojas, suprantantis bent vieną iš minėtų užsienio kalbų arba turintis techniškai taisyklingą vartotojo instrukciją. Prieš pradėdant dirbti su prietaisu privaloma perskaityti ir suprasti vartotojo instrukciją bei laikytis visų nurodytų reikalavimų. Prietaisas turi ATEX patvirtinimą remiantis EC-direktyvomis ir standartais. Vartotojai, nepriklausantys Europos Sąjungai, turi pasitikrinti jų šalyje galiojančius teisės aktus/reglamentus dėl pavojingų zonų.

## LV



Uzmanību: Piedāvātās iekārtas ar ATEX apstiprinājumu lietošanas instrukcija ir pieejama vācu, angļu un franču valodā (DVR 3: arī holandiešu valodā). Lietotājam ir atļauts darboties ar šo iekārtu tikai tajā gadījumā, ja viņš saprot vismaz vienu no augstāk minētām valodām vai ja ir nodrošināts pilns un tehniski pareizs lietošanas instrukcijas tulkojums. Pirms iekārtas darbināšanas lietošanas instrukciju ir jāizlasa un jāizprot, kā arī jāpiemēro visas nepieciešamās darbības. Iekārta ir ATEX apstiprināta, atbilstoši EK direktīvām un standartiem. Ārpus Eiropas Kopienas valstu lietotājiem ir jāpārbauda valsts nacionālos likumus par bīstamām zonām.

## NL



Attentie: de handleiding voor het geoffreerde apparaat met ATEX goedkeuring is beschikbaar in het Duits, Engels en Frans ( en voor de DVR 3 ook in het Nederlands). Het is de gebruiker alleen toegestaan om het apparaat te bedienen indien hij/zij een van deze talen begrijpt of indien er een technisch correcte vertaling van de complete handleiding beschikbaar is. De handleiding dient in zijn geheel gelezen en begrepen te worden en alle nodige maatregelen dienen geregeld te zijn alvorens het apparaat bedient mag worden. Het apparaat heeft een ATEX goedkeuring conform de EG-richtlijn en standaarden. Gebruikers buiten the Europese Gemeenschap moeten de nationale richtlijnen voor gevaarlijk locaties controleren.

## PL



Uwaga: Instrukcja oferowanego urządzenia z dopuszczeniem ATEX jest dostępny w języku niemieckim, angielskim i francuskim (DVR 3: również holenderskim). Użytkownik może korzystać z urządzenia tylko wtedy, gdy zapoznał się z instrukcją w jednym z podanych języków, lub poprawnym technicznym tłumaczeniem pełnej instrukcji. Przed użyciem instrukcja obsługi musi być przeczytana i zrozumiana, oraz wszystkie wymagane środki bezpieczeństwa muszą być przestrzegane. Urządzenie posiada certyfikat ATEX zgodnie z dyrektywami i normami. Użytkownicy spoza Wspólnoty Europejskiej powinni sprawdzić krajowe przepisy dla stref zagrożonych wybuchem.

## PT



Atenção: O manual do dispositivo oferecido com aprovação ATEX está disponível em Alemão, Inglês e Francês (DVR 3: também em holandês). O utilizador só é autorizado a operar o dispositivo se dominar um destes idiomas ou se tiver disponível um manual de operação completo, técnica e corretamente traduzido. O manual deverá ser lido e entendido na sua totalidade antes de se iniciar o funcionamento do dispositivo e todas as medidas necessárias deverão ser aplicadas.

O dispositivo tem uma aprovação ATEX de acordo com as diretivas e normas da Comunidade Europeia. Os utilizadores fora da Comunidade Europeia deverão verificar os regulamentos nacionais relativos às áreas de risco.

## RO



Atentie: Manualul aparatului este disponibil in urmatoarele limbi: germana, engleza si franceza (DVR 3: de asemenea si in olandeza).

Operatorul poate utiliza acest dispozitiv doar daca intelege una din aceste limbi sau exista o traducere tehnica corecta a manualului.

Manulul trebuie citit complet si inteles inainte de punerea in functiune a aparatului si toate cerintele solicitate trebuie aplicate.

Dispozitivul are aprobare ATEX conform cu directivele si standardele EC. Utilizatorii din afara comunitatii Europene trebuie sa verifice regulile specifice tarii lor si standardele pentru utilizarea aparatului intr-un mediu periculos.

## RU



Внимание: инструкция на предложенный аппарат с сертификатом ATEX доступна на немецком, английском и французском (DVR 3: также на датском).

Пользователю разрешено работать с прибором только, если он понимает один из этих языков или технически корректный полный перевод инструкции. Инструкция должна быть полностью прочитана и понята до начала работы с прибором, должны быть выполнены необходимые требования для работы прибора.

У прибора есть сертификат ATEX согласно стандартам ЕС. Пользователи вне ЕС должны проверять требования своих стран для работы в опасных областях.

## SE



Observera: Manualen om den erbjudna enheten med ATEX-godkännande finns på tyska, engelska och franska (DVR 3: även nederländska). Användaren är endast tillåten att använda enheten om han förstår något av dessa språk eller en tekniskt korrekt översättning av den fullständiga manualen. Manualen måste vara helt läsas och förstås innan drift av enheten och alla nödvändiga åtgärder måste tillämpas. Enheten har en ATEX-godkännande enligt EG-direktiv och standarder. Användare utanför Europeiska gemenskapen måste kontrollera nationella regler för farliga områden.

## SI



Opomba: navodila za uporabo za ponujeno napravo z odobritvijo ATEX je na voljo v nemškem, angleškem in francoskem jeziku (DVR 3: tudi nizozemščina). Uporaba naprave je dovoljena samo uporabnikom kateri so popolnoma prebrali in razumejo navodila v enem izmed ponujenih jezikov ali tehnično pravilen prevod celotnega priročnika.

Naprava ima ATEX odobritev v skladu z EC direktivami in standardi. Uporabniki zunaj Evropske skupnosti morajo preveriti nacionalne predpise za nevarna območja.

SK



Upozornenie: Návod pre ponúknutý prístroj s ATEX schválením je dostupný v nemeckom, anglickom alebo francúzskom jazyku (DVR 3: tiež v holandskom). Užívateľ môže používať prístroj iba v prípade ak rozumie jednému z týchto jazykov alebo technicky správnemu prekladu celého návodu na obsluhu. Je nutné si prečítať celý návod na obsluhu a pochopiť ho pred začatím práce s prístrojom a musí pritom dodržať všetky požadované opatrenia.

Prístroj má ATEX schválenie podľa požiadaviek kladených smernicami a normami Európskej únie. Užívatelia mimo Európskej únie si musia overiť platné národné predpisy kladené na priestory s nebezpečenstvom výbuchu.

TR



Dikkat : ATEX onayı ile sunulan cihazın kullanım kitabı Almanca, İngilizce ve Fransızca dillerinde mevcuttur (DVR3: ek olarak Hollanda dilinde). Kullanıcı bu dillerden birini tam olarak anladığı yada teknik olarak bütün kullanım kitabını kendi diline çevirebildiği durumda cihazı kullanabilir. Cihazın kullanımından önce kullanım kitabının tamamı okunmuş olmalı ve gerekli ölçümler yapılmış olmalıdır.

Cihaz EC-direktifleri ve standartlarına uygun ATEX onayına sahiptir. Avrupa Topluluğu dışında bulunan kullanıcılar, tehlikeli alanlar için kendi ülkelerinin düzenlemelerini kontrol etmelidirler.

# Contents

<b>Safety information!</b> .....	<b>11</b>
General information.....	11
Intended use.....	11
Setting up and installing the equipment .....	11
Ambient conditions.....	15
Operating conditions .....	15
Safety during operation .....	17
Maintenance and repair.....	18
<b>Notes regarding devices with ATEX conformity</b> .....	<b>19</b>
<b>Technical data</b> .....	<b>21</b>
Wetted parts.....	23
Pump parts.....	23
<b>Use and operation</b> .....	<b>28</b>
Installing in a vacuum system .....	28
During operation.....	34
Shutdown .....	36
<b>Circuit diagram</b> .....	<b>37</b>
<b>Troubleshooting</b> .....	<b>38</b>
<b>Maintenance of the diaphragm pump</b> .....	<b>39</b>
<b>Inspecting the overpressure safety valve</b> .....	<b>40</b>
<b>Repair - Maintenance - Return - Calibration</b> .....	<b>41</b>



➔ DANGER indicates a hazardous situation which, if not avoided, will result in death or serious injury.



⚠ WARNING indicates a hazardous situation which, if not avoided, could result in death or serious injury.



• CAUTION indicates a hazardous situation which, if not avoided, could result in minor or moderate injury.



NOTICE is used to address practices not related to personal injury.



Caution! Hot surface!



Isolate equipment from mains before removing the cover.



Electronic components must not be disposed of in the domestic waste at the end of their service life. Used electronic devices contain harmful substances that can cause damage to the environment or human health. End users are legally obliged to take used electric and electronic devices to a licensed collection point.



# Safety information!

## General information

### NOTICE

☞ **Read and comply with this manual before installing or operating the equipment.**

☞ Transport the pump at the provided handle.

Remove all packing material, remove the product from its packing-box, remove the protective covers from the inlet and outlet ports and keep, inspect the equipment.

If the equipment is damaged, notify the supplier and the carrier in writing within three days; state the item number of the product together with the order number and the supplier's invoice number. Retain all packing material for inspection.

**Do not use the equipment if it is damaged.**

If the equipment is not used immediately, replace the protective covers. Store the equipment in suitable conditions.

## Intended use

### WARNING

☞ Use the equipment for the intended use only according to the ATEX conformity, e. g. for pumping gas atmosphere without aerosol in a range from 0.1 to 1000 mbar and a maximum inlet pressure (dynamic pressure) and outlet pressure of 1100 mbar (absolute).

☞ The pump and all system parts must not be used on humans or animals.

☞ Prevent any part of the human body from coming into contact with vacuum.

☞ Ensure that the individual components are only connected, combined and operated according to their design and as indicated in the instructions for use.

☞ Comply with notes on correct vacuum and electrical connections, see section "Use and operation".

### CAUTION

The pumps are marked with "X" (according to DIN EN ISO 80079-36:2016), i. e. restrictions of the operation conditions:

- The pumps are designated for a low degree of mechanical stress and have to be installed in a way so that they can not be damaged from outside. Pumping units have to be installed protected against shocks from the outside and against glass splinters in the event of breaking (implosion).

- The pumps are designated for an ambient and gas inlet temperature during operation of +10 to +40°C. Never exceed these ambient and gas inlet temperatures.

### NOTICE

Use the equipment **for the intended use only**, i.e. for generation of vacuum in vessels designed for that purpose.

## Setting up and installing the equipment

### NOTICE

Before system start-up of the pump or the complete system the user has to evaluate in its entirety the **explosion risks** and takes adequate measures in application of the principle of risk assessment.

The evaluation and the measures have to be laid down in an **explosion protection document** before system start-up.

The pump/system must not be operated until operation without danger in explosive atmosphere is ensured. **Provide suitable control, protection and warning systems even in the event of failure.**

**The inner (pumped media) and outer part of the pump have to be evaluated separately because of their different conformity (see also section "Technical data" and "Notes regarding devices with ATEX conformity").**

The pumps are not suitable for pumping dust and have no approval for operation below ground.

The pumps are not suitable for pumping self inflammable substances, for substances which are inflammable without air and explosive substances.

## **WARNING**

- ☞ **Electrical and vacuum components might require a separate approval.**
- ☞ Include the components in the recurrent tests of tightness for pressure vessels, in the case of hits and beats an intermediate leak test is required.
- ☞ Due to the high compression ratio of the pumps, pressure at the outlet port might be generated being higher than the max. permitted pressure compatible with the mechanical stability of the system.
- ☞ Do not permit any **uncontrolled pressurizing** (e.g. make sure that the exhaust pipeline cannot become blocked). **Risk of bursting!**
- ☞ Always provide a free and pressureless exhaust pipeline.
- ☞ Ensure that the coolant outlet pipeline is always free and that it cannot get blocked. If there is an exhaust isolation valve, make sure that you cannot operate the equipment with the valve closed.

## **CAUTION**

- Secure coolant hoses at the hose nozzles (e.g. with hose clip) to prevent their accidental slipping.
- Comply with **maximum permissible pressures** at inlet and outlet and pressure differences, see section "Technical data". Do not operate the pump with overpressure at the inlet.
- **Attention:** Flexible elements tend to shrink when evacuated.

## **NOTICE**

Provide a firm level platform for the equipment and check that the system to be evacuated is mechanically stable and that all fittings are secure. Ensure a stable position of the pump without any mechanical contact except of the pump feet. Comply with all applicable **safety regulations**.

**Pumping units (pumps with vapour condenser) have to be installed protected against hits from outside and protected against splinters (against implosion). Adopt suitable measures prior to the first use.**

Obey all relevant requirements (regulations and guidelines) and **adopt suitable safety measures**.

## **WARNING**

- ☞ Pay attention to the max. permitted ambient temperature and make sure ventilation is adequate especially if pump is installed in a housing or if ambient temperature is elevated, install an external automatic ventilation system if necessary. If pumping hot process gases make sure that the maximum permitted gas inlet temperature is not exceeded.
- ☞ If the equipment is brought from cold environment into a room for operation, allow the equipment to warm up (pay attention to **water condensation** on cold surfaces).  
**Attention:** Flexible elements tend to shrink when evacuated.
- ☞ The work clothing of the user must not lead to **electrostatic discharge** which may ignite the explosive atmosphere.

## WARNING

### Inlet

- ☞ Connection lines at the pump inlet have to be performed **conductive grounded** and gas tight (designation of the pump connections see figures).
- ☞ The diameter of the inlet pipeline should be at the least as large as the diameter of the pump connection pipelines.
- ☞ Obey max. inlet pressure (see "Technical data").
- ☞ If there is a risk of **ignition** of gases or gas mixtures before or behind the pump the user has to provide suitable **safety devices against incoming of flames** according to EN 12874. The user must ensure the suitability concerning gas flow, chemical resistance and safeness against clogging prior to use.

## WARNING

### Outlet

- ☞ Connection lines at the pump outlet (small flange) have to be performed **conductive grounded** and gas tight (designation of the pump connections see figures).
- ☞ The diameter of the inlet pipeline should be at the least as large as the diameter of the pump connection pipelines.
- ☞ Obey max. inlet pressure (see "Technical data").

Due to the high compression ratio of the pumps, pressure at the outlet port might be generated being higher than the max. permitted pressure compatible with the mechanical stability of the system.

## WARNING

- ☞ Obey **maximum permitted pressures** and pressure differences, see section "Technical data". Do not operate the pump with overpressure at the inlet.
- ☞ Do not permit any **uncontrolled pressurizing** (e. g. make sure that the exhaust pipeline cannot become blocked). If you have an exhaust-isolation valve, make sure that you cannot operate the equipment with the valve closed. **Risk of bursting!**
- ☞ Ensure that the system design does not allow the **exhaust pipeline** to become blocked. Lead away exhaust gas or condensate at the outlet of the pump and the overpressure safety valve under consideration of all applicable safety measures. **Avoid backflow of gases or condensate definitely.**
- ☞ Ensure that the system design does not allow the **coolant outlet pipeline** to become blocked.
- ☞ Escaped and/or intentional or unintentional **released inflammable gases** or vapours which may lead to danger of explosion have to be lead away safely or lead to an appropriate place. If not possible enclose the gasses, vapours or mist safely or dispose in an other way. In case of mixtures or different gases the measures must consider the highest risk.
- ☞ If there is a risk of **ignition** of gases or gas mixtures before or behind the pump the user has to provide suitable **safety devices against incoming of flames** according to EN 12874. The user must ensure the suitability concerning gas flow, chemical resistance and safeness against clogging prior to use.

Check the **overpressure safety valve** at the outlet regularly.

## WARNING

- ☞ **Attention: If the exhaust pipeline is blocked the pumped gases may escape into the environment through the overpressure safety valve. If necessary take appropriate measures.**

If pumping dangerous gases install a second completely independent exhaust pipeline instead of the overpressure safety valve. If necessary assemble a hose nozzle instead of the overpressure safety valve to lead away the gases through a second exhaust pipeline. **Attention:** Never combine the exhaust pipelines, i. e. provide a sperate line for each exhaust.

## WARNING

### Inert gas purge

- ☞ The user must take suitable precautions to prevent any formation of explosive mixtures in the expansion chamber using inert gas to purge the housing. Otherwise in case of a diaphragm crack, mechanically generated sparks, hot surfaces or static electricity may ignite these mixtures.
- ☞ Inert gas connection lines (inlet and outlet) have to be performed conductive grounded and gas tight (designation of the pump connections see figures).
- ☞ Connect the **inert gas connections** at the crankcase not serial but parallel.
- ☞ We recommend an inert gas purge of  $\geq 1$  l per minute.
- ☞ Provide an external pressure limitation to a pressure of 1.1 bar absolute if **inert gas** is connected to the pump or at an air admittance valve. The inert gas has to be dry and pure. It could be recommendable to provide an appropriate **control system** to supervise the inert gas flow which switches off the pump in case of failure (e. g. absence of inert gas) if necessary.
- ☞ To control the faultless function of the diaphragm it could be recommendable install a **gas specific detector at the outlet of the inert gas purge**. A signal from the detector indicates a diaphragm crack. Switch off the pump immediately and check diaphragms.

## WARNING

- ☞ **It is possible to leave out the inert gas purge if the surrounding of the pump is zone 2 or not an explosive atmosphere.**
- ☞ **Without inert gas purge the pump outer part has the specification II 3G Ex h IIB T4 Gc X.**

## WARNING

### Gas ballast

- ☞ Use only inert gas for gas ballast.
- ☞ We recommend the use of gas ballast when pumping condensable media.
- ☞ Gas ballast connection lines (inlet and outlet) have to be performed conductive grounded and gas tight (designation of the pump connections see figures).
- ☞ Connect the **inert gas connections** at the gas ballast and the crankcase not serial but parallel.
- ☞ Provide an external pressure limitation to a pressure of 1.1 bar absolute if inert gas is connected to the pump or at an air admittance valve. The inert gas has to be dry and pure. It could be recommendable to provide an appropriate **control system** to supervise the inert gas flow which switches off the pump in case of failure (e. g. absence of inert gas) if necessary.

## WARNING

- Pumping at **high inlet pressure** may lead to overpressure at the gas ballast valve.
- ☞ Pumped gases or condensate might be pushed out in case the valve is open.
  - ☞ The inert gas lines have to be chemical resistant due to possible backflow.

## WARNING

### Electrical connection

- ☞ **Electrical connection** of the pump must be performed only by a suitable trained and supervised personnel.
- ☞ The motor cable for pumps in 230V version contains wires colour coded as follows: green or green and yellow: earth; blue or white: neutral; brown or black: live.
- ☞ The **earth connection of the device** (potential equalization) has to be performed only using the green or green/yellow earth connection wire. Connect the earth connection wire of the device to the earth connection of the power supply line and the potential equalization point of the environment of the device.
- ☞ When using pumps with two motors absolutely connect both motors as described above. Ensure that always both motors are running.

**Attention:** Never use the antistatic connection at the housing of the device to connect the device to ground, use only the green or green and yellow connection wire of the motor. Use the antistatic connection at the housing only to perform an antistatic connection of other non-electronic devices and components, e. g. inlet and outlet vacuum hoses or something similar. Never lead away short-circuit currents using this connection. External electric devices have to be connected at the potential equalization point of the environment separately and independent of this device.

## WARNING

- ☞ Equipment must be connected only to a suitable fused and protected electrical supply and a suitable earth point by suitable trained personnel. Failure to connect the motor to ground may result in deadly electrical shock. Check that mains voltage and current conform with the equipment (see rating plate).
- ☞ **Obey notes regarding the motor in section "Instructions manual: Explosion proof motors", see below.**

The motor is protected by a **thermal cutout with manual reset combined with an overcurrent protection.**

## WARNING

- ☞ Avoid reliable high heat supply (e. g. due to hot process gases). Maximum permitted gas and ambient temperature see "Technical data".
- ☞ Make sure ventilation is adequate especially if pump is installed in a housing or if ambient temperature is elevated, install an external automatic ventilation system if necessary.
- ☞ Ensure that in case of **pumps with two motors** both motors are switched on at the same time, if not possible switch on the motor of the pump at the outlet first.

### **Ambient conditions**

To the best of our knowledge the equipment is in compliance with the requirements of the applicable **EC-directives** and harmonized standards (see "Declaration of conformity") with regard to design, type and model, especially directive EN 61010-1. This directive gives in detail conditions, under which the equipment can be operated safely (see also IP degree of protection).

Adopt suitable measures in case of differences, e. g. using the equipment outdoors, installation in altitudes of more than 1000 m above mean sea level, conductive pollution or dewiness.

Pay attention to the **permissible maximum ambient and gas inlet temperatures** (see "Technical data").

### **Operating conditions**

The pumps have a conformity **according to their specification** to be installed in areas and to pump out of areas which contain **under normal operation conditions occasionally** a potential explosive atmosphere as a mixture of air with inflammable gases or vapours (**category 2**). **Class of ignition and temperature see "Technical data"**.

**The specification for category 2 for the outer part of the pump is only valid when purging the crankcase with inert gas. Without inert gas purging the pump has the specification II 3G Ex h IIB T4 Gc X for the outer part.**

Ensure that the materials of the wetted parts are compatible with the pumped substances, see section "Technical data".

## WARNING

- ☞ Adopt suitable measures to prevent the release of dangerous, explosive, corrosive or polluting fluids.
- ☞ If pumping **different substances**, it is recommended to purge the pump with air or inert gas prior to changing the pumped media in order to pump out residues and to avoid reactions of the pumped substances with each other and with the pump materials.  
**Take into consideration interactions and chemical reactions of the pumped media.** Ensure that the **materials of the wetted parts** are compatible with the pumped substances, see section "Technical data".
- ☞ The **valves and the diaphragms** are wear parts. **Replace the diaphragms and valves at the latest at 90% of the typical lifetime or immediately at higher noise level.** The typical lifetime of a diaphragm is 15000 operation hours when pumping non-corrosive or non-condensable gases, if necessary provide an operation time counter.
- ☞ Check the overpressure safety valve between the pump stages (only pumps with four cylinders) regularly and replace at the latest at 90% of the typical lifetime (typical lifetime: 15000 operation hours).
- ☞ Take adequate precautions to protect people from the effects of dangerous substances (chemicals, thermal decomposition products of fluoroelastomers), wear appropriate safety-clothing and safety glasses.
- ☞ Obey applicable regulations when disposing of chemicals. Take into consideration that chemicals may be polluted.
- ☞ Adopt suitable measures to prevent contamination of the pumped substances or the environment.

Electronic equipment is never 100% fail-safe. This may lead to an indefinite status of the equipment. Provide protective measures against malfunction and failure.

## WARNING

- ☞ Operating the pump, stand still of the pump or operating the air admittance valve must not lead to a critical dangerous situation under any circumstances.

Ensure that **in case of failure** the pump and the vacuum system always will turn into a safe status.

## WARNING

- ☞ In case of leaks in the manifold or diaphragm cracks pumped substances might be released into the environment or into the pump housing.
- ☞ Obey especially notes on operation and use and maintenance.
- ☞ Failure of the pump (e. g. by power failure) or connected components, parts of the supply (e. g. coolant) or change of parameters (e. g. increase of pressure in the coolant system) must not lead to a critical dangerous situation under any circumstances.

## Safety during operation



- ➔ Adopt suitable measures to prevent the release of dangerous, toxic, explosive, corrosive, noxious or polluting fluids, vapours and gases. In case install an appropriate collecting and disposal system and take protective action for pump and environment.
- ➔ Prevent any part of the human body from coming into contact with vacuum.
- ➔ Potentially explosive mixtures at the outlet of the pump have to be drained appropriately, sucked off or diluted with inert gas to non-explosive mixtures.



- ☞ Pay attention to the symbol "hot surfaces" on the equipment. Adopt suitable measures to prevent any danger arising from the formation of hot surfaces or electric sparks. Provide a suitable protection against contact if necessary.



- ☞ Always provide free and pressureless exhaust pipelines.
- ☞ Ensure that the **coolant outlet pipeline** is always free and that it cannot get blocked.
- ☞ Check liquid level in both catchpots regularly and drain condensate in time.



- ☞ Pumping at **high inlet pressure** may lead to overpressure at the gas ballast valve. Pumped gases or condensate might be pushed out in case the valve is open. If an inert gas supply is connected, ensure that the inlet pipeline is not contaminated.



- Comply with applicable regulations when disposing of chemicals. Take into consideration that chemicals may be polluted. Take adequate precautions to protect people from the effects of dangerous substances (chemicals, thermal decomposition products of fluoroelastomers), wear appropriate safety-clothing and safety glasses.



- ☞ Use only **genuine parts, genuine spare parts and genuine accessories**. Otherwise safety and performance of the equipment as well as the electromagnetic compatibility of the equipment might be reduced.
- ☞ **If not using genuine spare parts the ATEX conformity becomes invalid.**

Do not start the pump if the pressure difference between inlet and outlet port exceeds 1.1 bar at maximum.

Prevent the backpressure of gases and the backflow of condensates.

Never suck liquids or dust into the pump.

Ensure that in case of failure the pump and the vacuum system always will turn into a safe status.

Provide appropriate protective measures (i.e. precautions which allow for the requirements of the respective application) even for the case of failure and **malfunction**.

Failure of the pump (e.g. due to power failure) or of connected components, parts of the supply or change of parameters must not lead to a critical dangerous situation under any circumstances. In case of diaphragm cracks or leaks in the manifold pumped substances might be released into the environment or into the pump housing or motor. Comply especially with notes on operation and use and maintenance.

Due to the residual **leak rate of the equipment**, there might be an exchange of gas, albeit extremely slight, between the environment and the vacuum system.

Adopt suitable measures to prevent contamination of the pumped substances or the environment.

## Maintenance and repair

**Wear parts have to be replaced regularly.** In normal use, the lifetime of the diaphragms and valves is typically 15,000 operating hours. Bearings have a typical durability of 40000 h.



- The motor capacitors have to be replaced after 200000 start/stop cycles at the latest. If an overaged motor capacitor fails it might get hot and even melt and may cause a flame to form which could be **dangerous for persons and equipment in the vicinity**. The capacitors have to be replaced only at the factory.



Use only **genuine parts, genuine spare parts and genuine accessories**.

- ☞ Otherwise safety and performance of the equipment as well as the electromagnetic compatibility of the equipment might be reduced.
- ☞ **If not using genuine spare parts the ATEX conformity becomes invalid.**



Ensure that maintenance is done only by suitable trained and supervised technicians.

- ➔ **Isolate equipment from mains and wait two minutes** before starting maintenance to allow the capacitors to discharge.



- Before starting maintenance vent the pump, isolate the pump and other components from the vacuum system. Allow sufficient cooling of the pump. Drain condensate, if applicable.



- ☞ **Ensure that the pump cannot be operated accidentally. Never operate the pump if covers or other parts of the pump are disassembled. Never operate a defective or damaged pump.**

- ☞ **Attention:** The pump might be contaminated with process chemicals which have been pumped during operation. Ensure that the pump is decontaminated before maintenance and take adequate precautions to protect people from the effects of dangerous substances if contamination has occurred.

- ☞ Take adequate precautions to protect people from the effects of dangerous substances (chemicals, thermal decomposition products of fluoroelastomers), wear appropriate safety-clothing and safety glasses.
- ☞ To avoid danger due to electrostatic ignition wipe the device or parts of the device only with a humid cloth.

In order to comply with law (occupational, health and safety regulations, safety at work law and regulations for environmental protection) vacuum pumps, components and measuring instruments returned to the manufacturer can be repaired only when certain procedures (see section "**Repair - Maintenance - Return - Calibration**") are followed.

## Notes regarding devices with ATEX conformity

### **This information sheet does not replace the instructions for use!**

In directive 89/391/EEC the European Union has defined requirements for safety at work, which later have been detailed for explosive atmospheres in the directive 1999/92/EC.

The requirements to equipment for operation in explosive atmospheres have been defined in the directive 94/9/EC, since April 20th 2016 in directive 2014/34/EU (also known as ATEX 100a or ATEX 95).

Concerning technology these directives only state general requirements. Technical details and test procedures are "recommended" in European standards (e.g. for equipment with ATEX conformity: EN 1127, E50014ff, EN 60079, DIN EN ISO 80079-36:2016).

Since July 1st 2003 equipment intended for use in potentially explosive atmospheres shall only be sold if the equipment is in accordance with directive 94/9/EG (ATEX), since April 20th 2016 in accordance with directive 2014/34/EU. This applies only to new equipment. The repair of equipment sold prior to July 1st, 2003 is not affected. EX approvals according to directive 94/9/EC remain valid under 2014/34/EU.

### **Requirements to users and manufacturers of equipment according to ATEX:**

The **user of a system according to ATEX** has to analyse the overall explosion risks according to directive 1999/92/EC and has to take adequate measures by means of a risk assessment. The evaluation and validation of measures has to be documented in an explosion protection document, specifying among other things the areas classified as potentially explosive (see below). The inner part of the pump (pumped gases) and the environment of the pump (outer explosion protection) have to be evaluated separately. Often the requirements will be different.

**The responsibility for the classification of areas with potentially explosive atmospheres into zones and for the specification of requirements to the equipment (category of equipment, class of ignition, temperature class etc.) is accountable strictly to the operator of the system. The equipment used has to comply with these requirements. VACUUBRAND does not advise customers concerning requirements to the equipment under the specific aspects of the customer's applications.**

**Equipment with ATEX-conformity is to be used by appropriately instructed personnel only.**

### **ATEX marking, intended use:**

The marking of the equipment corresponding with the standards (see above) gives the areas in which the equipment may be used according to its intended use.

**Technical data, safety notes and intended use:  
See instructions for use!**

**The equipment must not be used if the instructions for use are not read, fully understood and obeyed.**

**Clean, check and maintain equipment regularly.**

**Do never operate a defective equipment.**

### **Electrical connection:**

VACUUBRAND diaphragm pumps with ATEX-conformity (device cat. 2) are equipped with a 230 V / 50 Hz single-phase motor and are protected by a thermal cutout with manual reset combined with an overcurrent protection.

**See instructions for use concerning notes on electrical connection.**

Where applicable the motors can be connected directly to an appropriate power supply by suitably trained and authorised personnel (electrician). It is the responsibility of the user to meet the requirements of explosion protection in the power supply and connection area.

For operation of VACUUBRAND ATEX VARIO pumps a motor speed control signal (4 – 20 mA) is required.

### **Vacuum and outlet connections:**

**See instructions for use: Make sure that all mechanical connections are always gas tight and electrically conducting.**

**The exhaust pipeline must be designed in a way that it cannot become blocked.**

If the exhaust pipeline becomes blocked, the overpressure safety device at the pump releases potentially dangerous gases into the environment. Take appropriate safety measures (see instructions for use).

**Evaluate the risk of explosion for the release of pumped gases at the outlet of the pump.**

### **Use and connection of inert gas supply:**

For external ATEX equipment category 2G (e.g. for use in Ex-zone 1) the crank case of the pump has to be flushed with inert gas (e.g., nitrogen). A flow of approx. 1 l/min (at atmospheric pressure up to max. 0.1 bar over pressure) is sufficient. If necessary the flow should be monitored using a flow meter. Without inert gas purge the pump has external equipment category 3G. This means the pump has to be used in this case only in a surrounding with Ex - zone 2 (or no Ex-zone).

It is recommended to install a gas detector (specific to the pumped gas) at the outlet of the inert gas tubing. The maximum permitted overpressure at the inert gas outlet is 0.1 bar (check the flow rate through the gas detector!). A positive signal from the detector indicates a diaphragm failure. In this event switch off the pump immediately and check the pump.

**In the case of pumping condensable vapours, use gas ballast. Connect inert gas with maximum overpressure of 0.1 bar to the gas ballast inlet (see instructions for use).**

**Inlet of air into the gas ballast must never lead to formation of an explosive mixture inside the pump  
or at the outlet of the pump!**

## Technical data

Type		MZ 2C EX MZ 2C EX + AK + EK	MD 4C EX MD 4C EX + AK + EK	MV 10C EX MV 10C EX + AK + EK
ATEX approval Inner part (pumped gases) Outer part Surrounding of the pump with inert gas purge Surrounding of the pump without inert gas purge		II 2G Ex h IIC T3 Gb X  II 2G Ex h IIB T4 Gb X II 3G Ex h IIB T4 Gc X		
ATEX approval Motor		II 2G Ex db IIB T4 Gb		
Max. pumping speed* according to ISO 21360	m <sup>3</sup> /h	1.9	3.7	8.1
Ultimate vacuum* (absolute) without gas ballast	mbar	12	3	2
Ultimate vacuum* (absolute) with gas ballast	mbar	18	10	10
Max. permitted pressure at the inlet and the outlet (absolute)	bar	1.1		
Max. permitted pressure difference between inlet and outlet	bar	1.1		
Max. permitted pressure at inert gas connection (absolute)	bar	1.1		
Max. permitted ambient temperature during operation	°C	+10 to +40		
Max. permitted ambient temperature during storage	°C	-10 to +60		
Permitted gas inlet temperature	°C	+10 to +40		
Max. surface temperature of the pump (outer part)	°C	110		
Max. permitted atmospheric moisture during operation (no condensation)	%	30 to 85		
Degree of protection of the pump IEC 529 Pump Pump + AK + EK		IP 54** IP 52**	IP 54** IP 54**	IP 54** IP 54**
Nominal current draw	A	1.2	2	2 x 2
Maximum start-up current / Start-up duration		5.5 A / 125 ms	10.2 A / 125 ms	2 x 10.2 A / 125 ms

\* Technical data according to EN 61010-1 and EN 1012-2 recommendation. The pump achieves its ultimate pumping speed and ultimate vacuum only at operating temperature (after approx. 15 min.).

\*\* Only when positioning the pump horizontal.

**We reserve the right for technical modifications without prior notice!**

Type		<b>MZ 2C EX</b> <b>MZ 2C EX +</b> <b>AK + EK</b>	<b>MD 4C EX</b> <b>MD 4C EX +</b> <b>AK + EK</b>	<b>MV 10C EX</b> <b>MV 10C EX +</b> <b>AK + EK</b>
Max. permitted range of voltage supply / frequency		230V ± 10% / 50 Hz		
Integral leak rate	mbar*l/s	0.1		
Motor power	kW	0.15	0.25	2 x 0.25
No-load speed	min <sup>-1</sup>	1500		
A-weighted emission sound pressure level*** (uncertainty K <sub>PA</sub> : 3 dB(A))	dB(A)	50	53	53
Inlet Pump		KF 16	KF 25	KF 25
Outlet Pump Pump + AK + EK		KF 16 hose nozzle 10 mm		
Gas ballast connection		hose nozzle 10 mm		
Inert gas purge connection		hose nozzle 8 mm		
Recommended flow of inert gas	l/min	≥ 1		
Overall dimensions L x B x H, approx.				
Pump	mm	337 x 287 x 251	440 x 265 x 305	560 x 430 x 410
Pump + AK + EK	mm	357 x 308 x 466	600 x 365 x 420	649 x 525 x 452
Mass, approx.				
Pump	kg	23.1	30.2	63.2
Pump + AK + EK	kg	27.5	38.5	68.0

\*\*\* Measurement according to EN ISO 2151:2004 and EN ISO 3744:1995 at 230V/50Hz and ultimate vacuum with exhaust tube at outlet.

**We reserve the right for technical modifications without prior notice!**

### Wetted parts

Components	Wetted parts
Inlet	stainless steel*
Outlet Pump Pump + AK + EK	stainless steel** PBT
Hoses	PTFE, antistatic
Fittings	ETFE / stainless steel*
Housing cover insert	PTFE, carbon reinforced
Head cover	ETFE, carbon reinforced
O-ring in head cover	FPM
Diaphragm clamping disc	ETFE, carbon reinforced
Valve	FFKM or PTFE
Diaphragm	PTFE
Overpressure safety relief device	stainless steel***, PTFE, carbon reinforced, FFKM
Separator cover plate	PTFE, carbon reinforced
O-ring at the catchpot at the inlet	FFKM
Catchpot, collecting flask, vapour condenser	borsilicate glass

\* stainless steel 1.4404

\*\* stainless steel 1.4541

\*\*\* stainless steel 1.4404 and 1.4310

### Pump parts

Position	Component	Position	Component
1	inlet (vacuum connection)	12	exhaust waste vapour condenser
2	outlet (gas!)	13	coolant inlet (hose nozzle 6 mm)
3	on/off switch	14	coolant outlet (hose nozzle 6 mm)
4	rating plate	15	catchpot
5	handle	16	cover plate
6	gas ballast connection (only inert gas)	17	collecting flask
7	inlet inert gas purge		
8	outlet inert gas purge		
9	overpressure valve		
10	antistatic connection		
11	mains cable		

**We reserve the right for technical modifications without prior notice!**

### MZ 2C EX

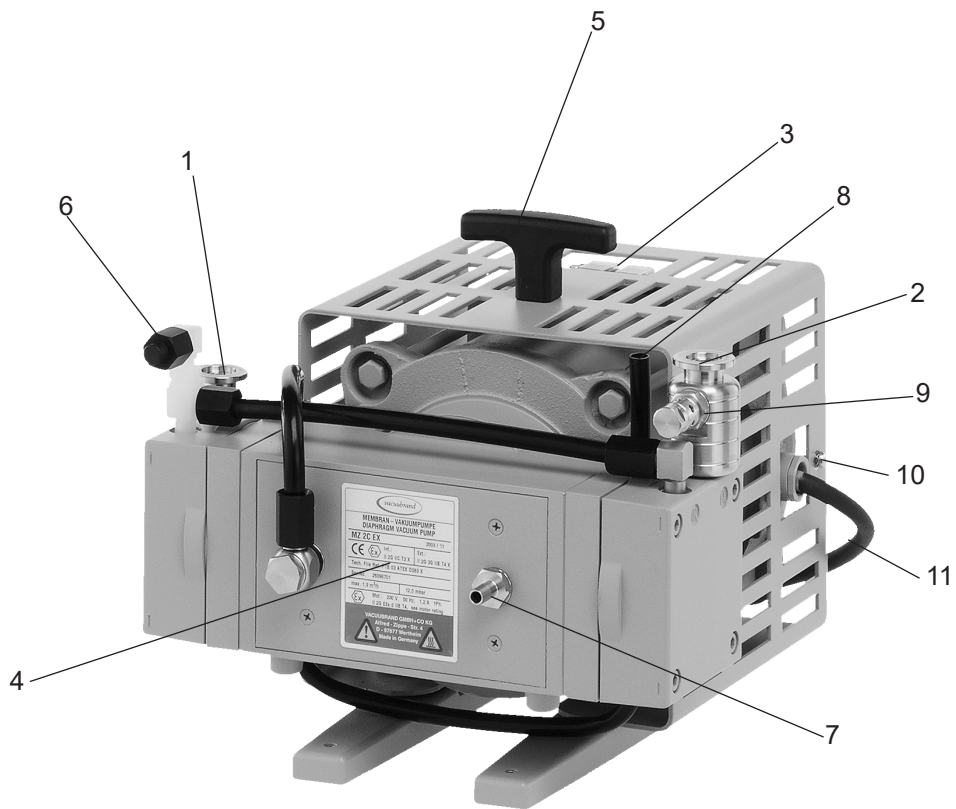

### MD 4C EX

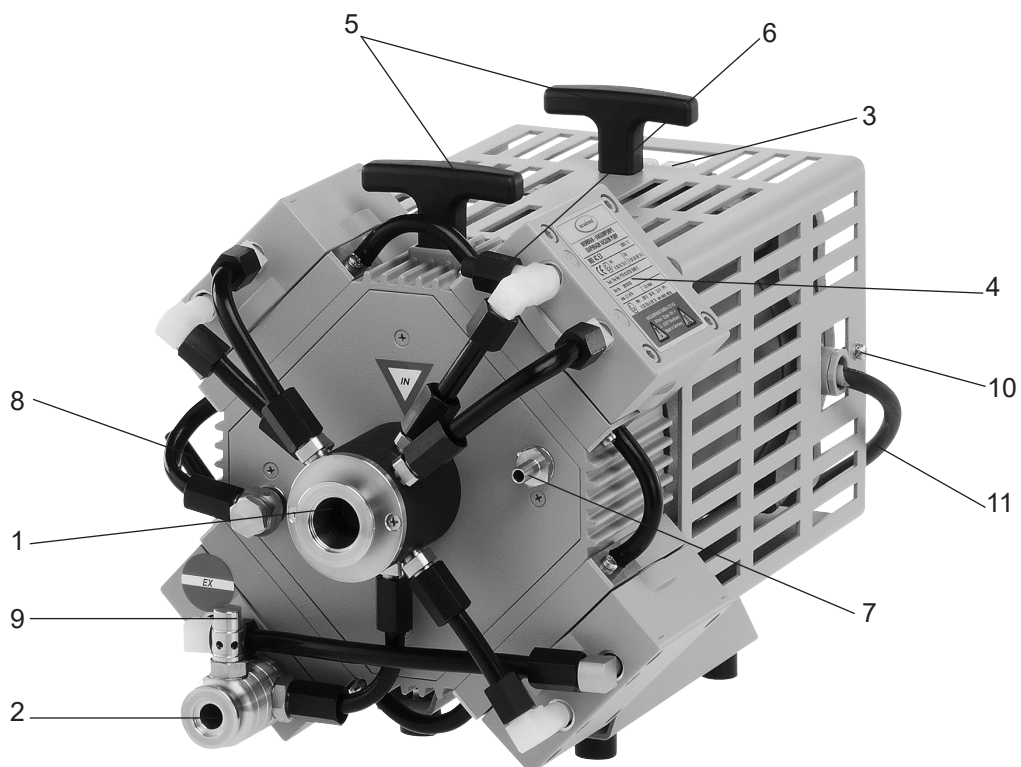

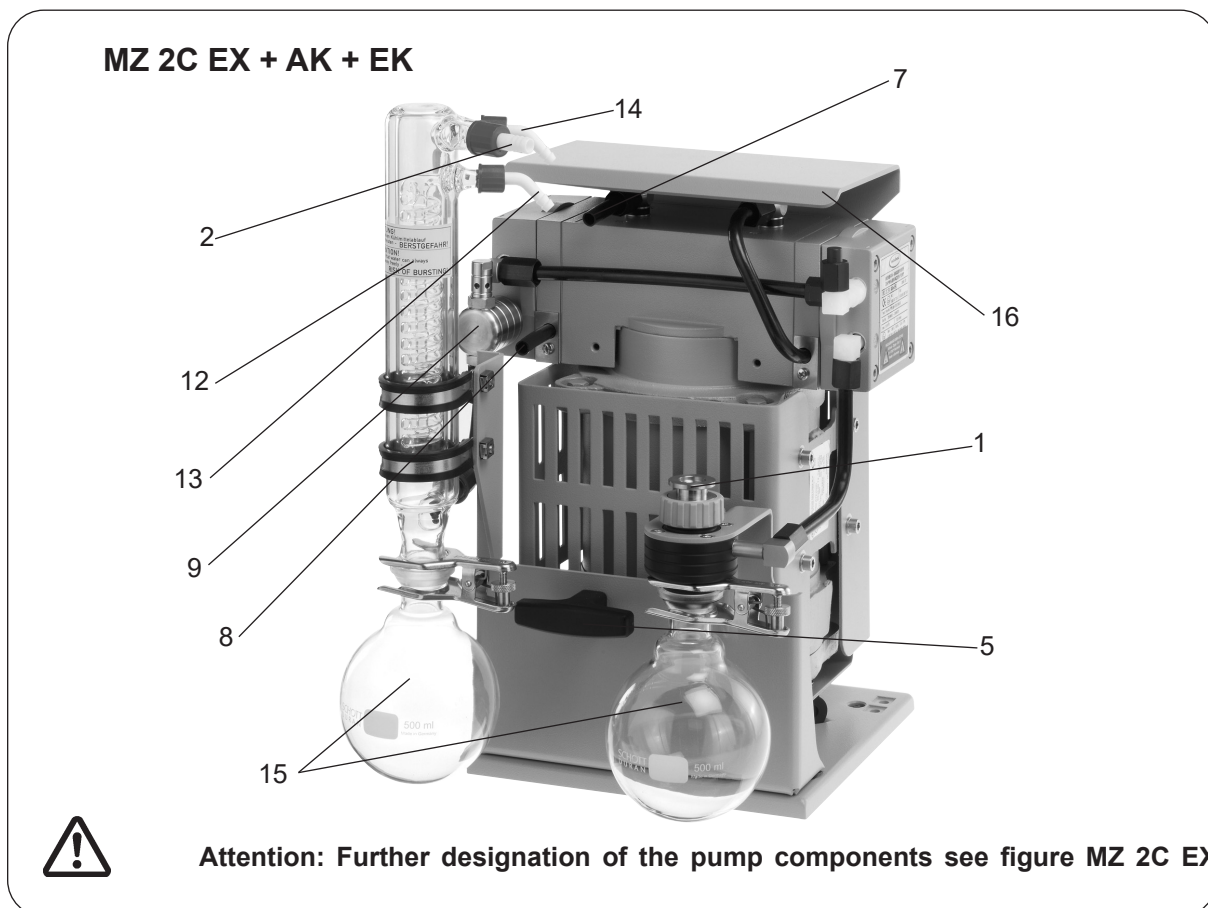
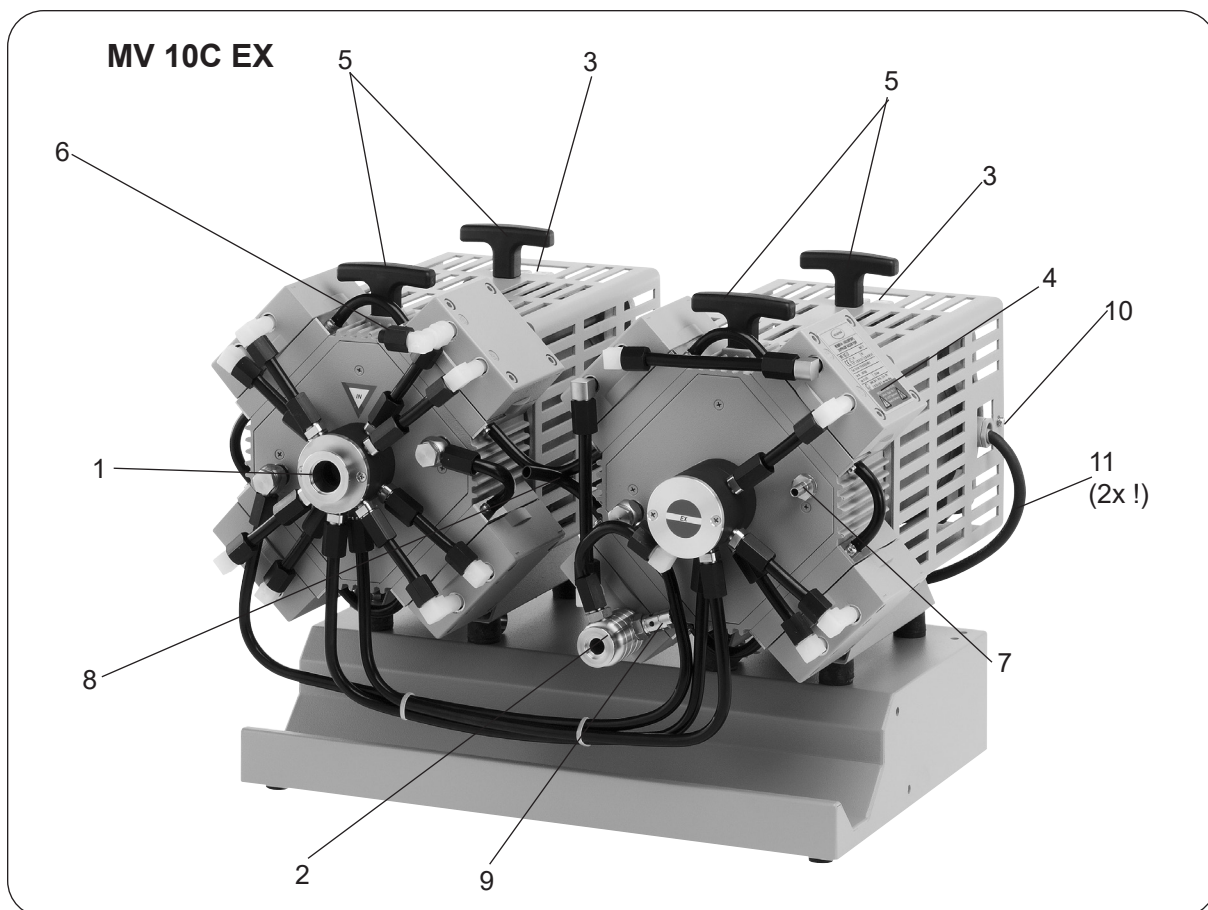

**Attention: Further designation of the pump components see figure MZ 2C EX**

### MZ 2C EX + AK + EK (rear side)

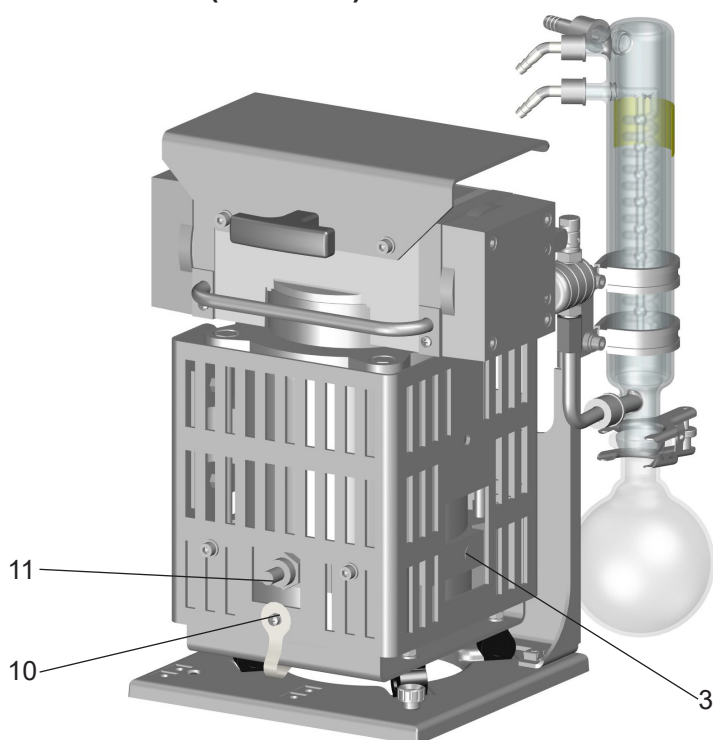

Attention: Further designation of the pump components see figure MZ 2C EX

### MD 4C EX + AK + EK

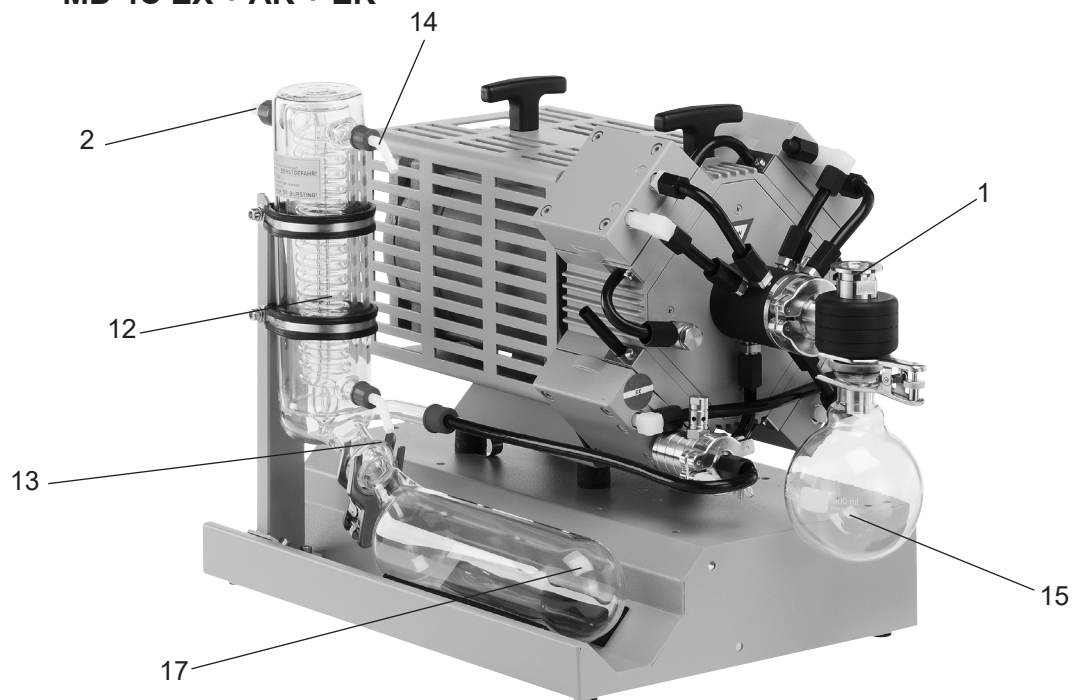

Attention: Further designation of the pump components see figure MD 4C EX

### MV 10C EX + AK + EK

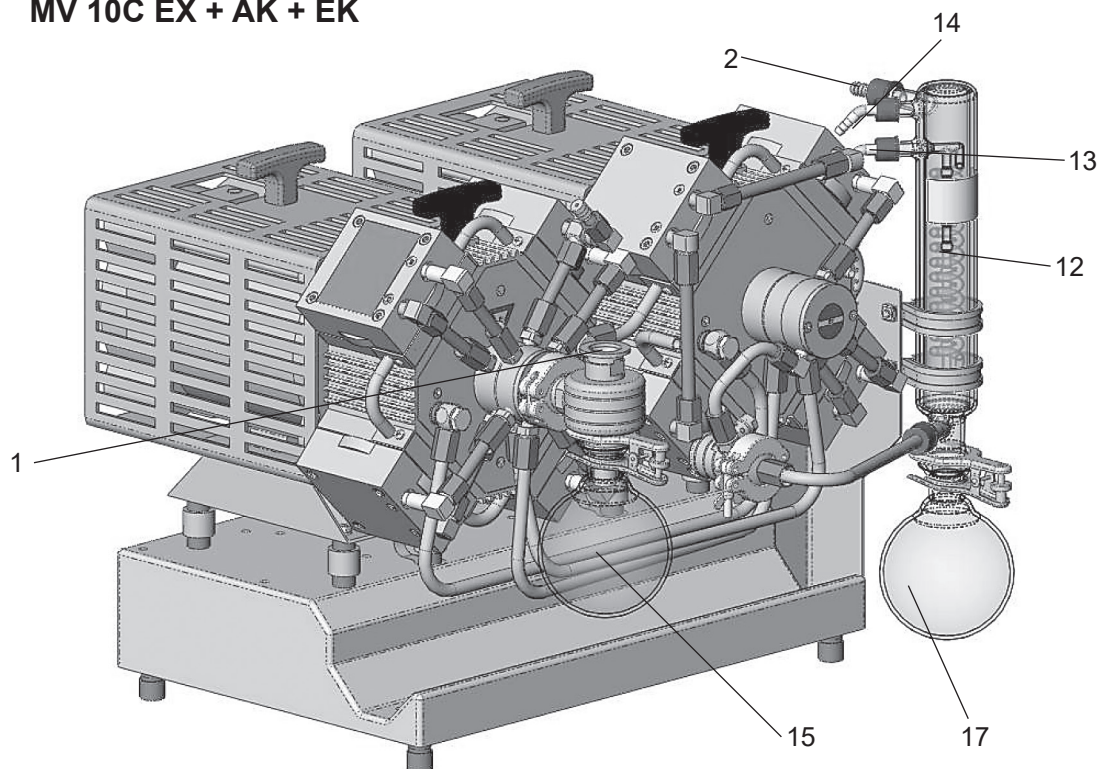

**Attention:** Further designation of the pump components see figure MV 10C EX

## Use and operation

### *Installing in a vacuum system*

#### CAUTION

- All connection lines at the pump (e. g. inlet, outlet, gas ballast connection, inert gas connection) have to be **performed conductive grounded**.
- Connect pump and all connected components to ground.
- Avoid contact of the pump with **rusty metal parts**, e. g. by positioning the pump with sufficient distance to surrounding parts.
- The pump is designated for a low degree of mechanical stress. Protect the pump from damage and beats. In case of damage switch off the pump immediately, check leak rate if necessary.
- Connection lines at the pump inlet have to be gas tight. Particles and dust must not be aspirated, the user has to provide appropriate filters if necessary. The user must ensure their suitability concerning gas flow, chemical resistance and safety against clogging prior to use.
- Connect an exhaust line gas tight at the pump outlet if necessary. Always dispose of exhaust gases appropriately (e.g. into a fume hood). If there is risk of release of dangerous or polluting fluids, install an appropriate system to catch and dispose of those fluids.
- Reduce the transmission of vibration and prevent mechanical load due to rigid pipelines. Insert elastic hoses or flexible elements as couplings between the pump and rigid pipes. **Attention:** Flexible elements tend to shrink when evacuated.
- Use of a suitable valve to isolate the pump from the vacuum system is recommended to allow the pump to warm up before pumping condensable vapours or to clean the pump before it is switched off.
- The gas outlet must never be blocked. The exhaust line has always to be free (pressureless) to ensure an unimpeded discharge of gas.
- Especially if the gas ballast valve is open, a power failure may cause accidental ventilation of the pump. In case this constitutes a potential source of danger, take appropriate safety measures.
- Make sure ventilation is adequate especially if the pump is installed in a housing or if the ambient temperature is elevated. Provide external ventilation if necessary. Keep a distance of minimum 20 cm between fan and ambient parts.

#### NOTICE

Avoid throttling losses by using connecting pipes with large diameter and by keeping them as short as possible.

In case of perturbing exhaust noise connect an exhaust hose. Install outlet pipelines always falling to avoid backflow of condensate towards the pump.

When assembling, ensure **vacuum-tightness**. After assembly, check the whole system for leaks. Secure hose connections at the pump appropriately against accidental detaching.

#### NOTICE

Attach the pipelines of the coolant circuit to the respective hose nozzles (hose nozzles 6-8 mm, see image) at the vapour condenser. Check hose connections prior to starting operation of the cooling system.

Secure coolant hoses at the hose nozzles (e.g. with hose clip) to prevent their accidental slipping.

## CAUTION

- The gas outlet must not be blocked. The exhaust pipeline has always to be free and pressureless to enable an unhindered discharge of gases.
- If necessary connect the exhaust to a suitable treatment plant to prevent the discharge of dangerous gases and vapours to the surrounding atmosphere.
- **Attention:** Install hoses of the cooling system in a way to avoid flow / dropping of condensed water onto the pumping unit (especially cables and electronic parts).
- Ensure that the **coolant outlet pipeline** is always free and that it cannot get blocked.
- Install an optional coolant valve always in the supply line of the vapour condenser only.

### Connection of the mains cable

## WARNING

- ☞ **Electrical connection** of the pump must be performed only by a suitable trained and supervised personnel.
- ☞ The motor cable for pumps in 230V version contains wires colour coded as follows: green or green and yellow: earth; blue or white: neutral (N); brown or black: live (L).
- ☞ Provide a fuse for the mains cable (L and N) according to the current draw of the motor, see "Technical data".
- ☞ The **earth connection of the device** (potential equalization) has to be performed only using the green or green/yellow earth connection wire. Connect the earth connection wire of the device to the earth connection of the power supply line and the potential equalization point of the environment of the device.  
**Attention:** Never use the antistatic connection at the housing of the device to connect the device to ground, use only the green or green and yellow connection wire of the motor. Use the antistatic connection at the housing only to perform an antistatic connection of other non-electronic devices and components, e. g. inlet and outlet vacuum hoses or something similar. Never lead away short-circuit currents using this connection. External electric devices have to be connected at the potential equalization point of the environment separately and independent of this device.
- ☞ In case of **power failure** unintentional venting of the system is possible. Adopt suitable measures if this might lead to a dangerous situation.

### Inlet

## WARNING

- ☞ Connection lines at the pump inlet have to be performed conductive grounded and gas tight (designation of the pump connections see figures).
- ☞ **Particles and dust** must not be aspirated, the user has to provide appropriate filters if necessary. The user must ensure the suitability concerning gas flow, chemical resistance and safeness against clogging prior to use.
- ☞ If there is a danger of **deposits** in the pump chamber (check inlet and outlet of the pump) control the pump chamber regularly and clean if necessary.
- ☞ If there is a risk of **ignition** of gases or gas mixtures before or behind the pump the user has to provide suitable **safety devices against incoming of flames** according to EN 12874. The user must ensure the suitability concerning gas flow, chemical resistance and safeness against clogging prior to use.

### Connection of the inert gas purge

## WARNING

- ☞ Connect the **inert gas connections** at the gas ballast and the crankcase not serial but parallel.
- ☞ Inert gas connection lines (inlet and outlet) have to be performed conductive grounded and gas tight (designation of the pump connections see figures).
- ☞ We recommend an inert gas purge of  $\geq 1$  l per minute.

## WARNING

- ☞ To control the faultless function of the diaphragm it could be recommendable to install a **gas specific detector** at the outlet of the inert gas purge. A signal from the detector indicates a diaphragm crack. Switch off the pump immediately and check diaphragms.
- ☞ If the surrounding of the pump is not an explosive atmosphere it is possible to leave out the inert gas purge.

### Connection of the inert gas ballast

## WARNING

- ☞ Connect the **inert gas connections** at the gas ballast and the crankcase not serial but parallel.
- ☞ Use only inert gas at the gas ballast connection. Therefore replace the blind cap at the gas ballast connection by the hose nozzle enclosed.
- ☞ Gas ballast connection lines (inlet and outlet) have to be performed conductive grounded and gas tight (designation of the pump connections see figures).
- ☞ Provide an external pressure limitation to a pressure of 1.1 bar absolute if inert gas is connected to the pump or at an air admittance valve. The inert gas has to be dry and pure. Provide an appropriate control system to supervise the inert gas flow which switches off the pump in case of failure (e. g. absence of inert gas) if necessary.

#### **Attention: Important notes regarding the use of gas ballast**

- ☞ When using air rather than inert gas, risk of significant damage to equipment and/or facilities, risk of personal injury or even loss of life exists due to the formation of hazardous and/or explosive mixtures if air and pumped media react inside or at the outlet of the pump.

### Outlet of the pump

## WARNING

- ☞ Always connect an exhaust line at the pump outlet (small flange or hose nozzle 10 mm). **Perform the outlet line conductive grounded and gas tight** (designation of the pump connections see figures). Always connect the exhaust to a suitable treatment plant (e. g. hood).
- ☞ **Potential explosive mixtures at the outlet of the pump have to be drained appropriately, sucked off or diluted with inert gas not explosive mixtures.**
- ☞ If there is a danger of **deposits** in the pump chamber (check inlet and outlet of the pump) control the pump chamber regularly and clean if necessary.
- ☞ If there is a risk of **ignition** of gases or gas mixtures before or behind the pump the user has to provide suitable **safety devices against incoming of flames** according to EN 12874. The user must ensure the suitability concerning gas flow, chemical resistance and safeness against clogging prior to use.

### Overpressure safety valve at the outlet of the pump

## WARNING

- ☞ The **overpressure safety valve** at the outlet prevents reliable high pressures in the system. Check overpressure safety valve regularly and replace if necessary.
- ☞ **Attention:** If the exhaust pipeline is blocked the pumped gases may escape into the environment through the overpressure safety valve. If necessary take appropriate measures.

If pumping dangerous gases install a second completely independent exhaust pipeline instead of the overpressure safety valve. If necessary assemble a hose nozzle (thread G 1/4) instead of the overpressure safety valve to lead away the gases or condensate through a second exhaust pipeline. **Attention:** Never combine the exhaust pipelines, i. e. provide a separate line for each exhaust.

## DANGER

**Attention:** Deposits and condensate may lead to increased temperature and to excess of the max. permitted temperatures! Increased temperatures possibly may lead to ignition of flammable mixtures inside the pump.  
Use inert gas ballast if necessary and check pump regularly for deposits.  
Install a gas washing bottle, condenser, filter, separator, etc. at the inlet of the pump if necessary.

### Pumps with two motors



- ☞ Ensure that in case of pumps with two motors both motors are switched on at the same time, if not possible switch on the motor of the pump at the outlet first.
- ☞ Connect the inert gas connections at the crankcase not serial but parallel.



**Attention:** Glass parts (flasks and condensers) of pumping units (pumps with AK (IK) and EK) have no protection against splinters (against implosion) or against leakage in case of mechanical damage or hits from outside.

The user must ensure an **appropriate protection against splinters / implosion** or leakage **prior to the first use.**

### Pumps with glass parts



- ☞ To avoid electrostatic charging, friction against glass parts in potentially explosive atmospheres is not permitted.

### Adhesive labels on the pump



- ☞ To avoid electrostatic charging, the removal of rating plates and adhesive labels in potentially explosive atmospheres is not permitted.

### MZ 2C EX + AK + EK

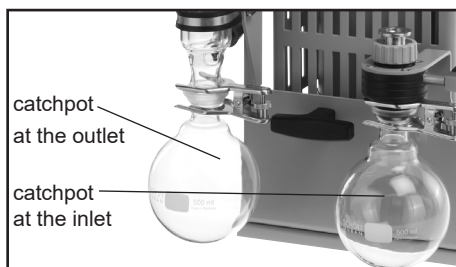

➔ Assemble **catchpot** at the inlet and at the outlet using joint clips.

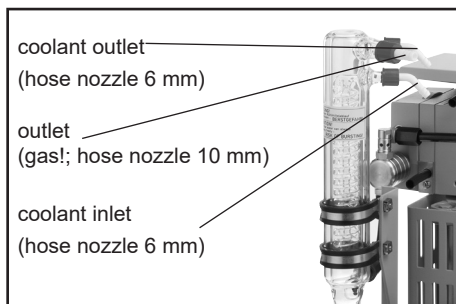

➔ Assemble **hose nozzles** for cooling water inlet and outlet at the vapour condenser.

### MD 4C EX + AK + EK / MV 10C EX + AK + EK

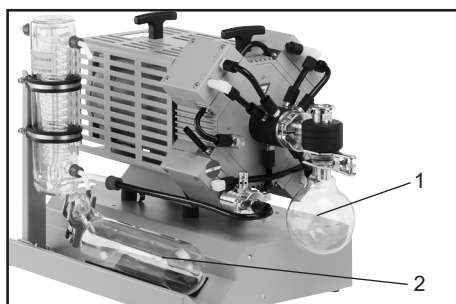

➔ Assemble catchpot at the inlet (1) using joint clips.  
 ☞ The collecting flask at the outlet (2) is already assembled.

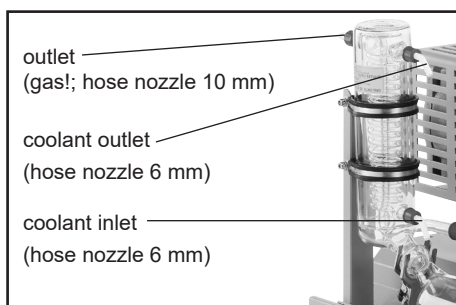

➔ Assemble hose nozzles for cooling water inlet and outlet at the vapour condenser.

### Spare part

O-Ring 28 x 2.5 ..... **20635628**  
 at the spherical ground joint of the catchpot at the inlet

### Separation of condensate:

**Attention: Due to electrostatics reasons the vapour condenser has no protective layer to avoid separation of condensed water! Risk of bursting!**

## CAUTION

- Maximum permissible coolant pressure at the vapour condenser: 6 bar (absolute). Backflow always pressureless.
- Comply with the maximum permissible coolant pressures of additional components in the coolant circuit (e.g. coolant valve).
- Avoid overpressure in the coolant circuit (e.g. caused by blocked or squeezed coolant hoses).
- Install an optional coolant valve always in the supply line of the vapour condenser only.

Permissible range of coolant temperature at the vapour condenser:  
-15°C to +20°C

Check hose connections prior to starting operation of the cooling system.  
Check coolant hoses regularly during operation.

Do not allow the catchpots to get overfilled. Maximum liquid level approx. 80% to avoid problems when removing the catchpots.  
Check liquid level in both catchpots regularly and drain catchpots in time.

### Removing the catchpots:

Catchpot / collecting flask at outlet:

Remove joint clip, remove catchpot and drain condensate.

Catchpot at inlet:

Admit air or inert gas (via pump inlet) to atmospheric pressure. Remove joint clip, remove catchpot and drain condensate.

- Reassemble drained catchpots.

**Important:** Comply with regulations when disposing of solvents/condensates. Re-use if possible, purify if contaminated.

## WARNING

For **condensable vapours** (water vapour, solvents, ...):

- ☞ Do not pump vapour before pump has reached its operating temperature and without inert gas ballast.
- ☞ Use inert gas at the gas ballast to avoid the formation of explosive mixtures.
- ☞ With gas ballast ultimate vacuum will be reduced
- ☞ Do not pump vapour before pump has reached its operating temperature

In case of low boiling solvents when the formation of condensate is unlikely, the use of gas ballast might be unnecessary.

Operating the pump without gas ballast increases the solvent recovery rates at the vapour condenser.

The **exhaust waste vapour condenser enables** an efficient condensation of the pumped vapours at the outlet.

- ☞ Next to 100% solvent recovery.
- ☞ Install hoses for cooling water at the inlet and outlet (hose nozzle 6 mm), secure hose connections against gliding down.
- ☞ Ensure that the system design does not allow the **coolant outlet pipeline** to become blocked.

## WARNING

## WARNING

- ☞ Ensure that the system design does not allow the exhaust pipeline to be blocked (hose nozzle 10 mm), do not permit uncontrolled pressurizing.
- ☞ Connect the exhaust to a suitable treatment plant to prevent the discharge of dangerous gases and vapours to the surrounding atmosphere.
- ☞ The pumped gases at the outlet of the pump or at the exhaust waste vapour condenser have to be drained under consideration of all applicable safety regulations.

The user has to check the possibility of an explosive atmosphere at the outlet of the pump or the exhaust waste vapour condenser. Therefore for example calculate the solvent partial pressure at the present cooling water temperature at the exhaust waste vapour condenser and compare with the explosion limits of the pumped solvent. If there is an explosive mixture, drain the gas at the outlet in antistatic lines according to the valid explosion protection guidelines.

### *During operation*

## CAUTION

- **Maximum ambient temperature:** 40 °C
- Make sure ventilation is adequate especially if the pump is installed in a housing or if the ambient temperature is elevated. Install an external **automatic ventilation system** if necessary.
- If the pump is installed in altitudes of more than 1000 m above mean sea level check compatibility with applicable safety requirements, especially IEC 60034 (motor might overheat due to insufficient cooling).
- **If the pump has been exposed to increased ambient temperature (> 40°C)** check the pump for damage and perform a leak test if necessary (integral leak rate < 0.1 mbar\*l/s).
- **Potentially explosive gases and vapors** at the outlet of the pump have to be drained appropriately.
- Due to the high compression ratio of the pumps, pressure at the outlet port might be generated being higher than the max. permitted pressure compatible with the mechanical stability of the system. Ensure that the pump outlet is not blocked or restricted.

Do not start pump if **pressure difference between inlet and outlet port exceeds max. 1 bar**. Attempts to start pump at higher difference may cause blockade and damage of the motor. Check compatibility with **maximally permitted pressure** at inlet and outlet.

Due to the high compression ratio of the pumps, pressure at the outlet port might be generated being higher than the max. permitted pressure compatible with the mechanical stability of the system.

## WARNING

- ☞ Check compatibility with **max. permitted pressure** at the inlet and the outlet and **max. pressure difference** between inlet and outlet ports.

Check the pump regularly at the outside for **pollution** or deposits, clean the pump if necessary to avoid increase of the operation temperature of the pump.

If pumping different substances purge the pump with inert gas prior to change the pumped media to pump out residues and to avoid reactions of the pumped substances with each other and the pump material.

Take into considerations interactions and chemical reactions of the pumped media.

The pump achieves its **pumping speed, ultimate total vacuum** and vapour pumping rate only at operating temperature (after approx. 15 minutes).

## **WARNING**

- ☞ Prevent internal condensation, transfer of liquids or dust. The diaphragm and valves will be damaged, if liquids are pumped in significant amounts. Check the pump regularly at the outside for pollution or deposits, clean the pump if necessary to avoid increase of the operation temperature of the pump.
- ☞ Let the pump **run with gas ballast** to reduce condensation of pumped substances (water vapour, solvents, ....) in the pump.

The motor is protected by a **thermal cutout with manual reset combined with an overcurrent protection.**

## **NOTICE**

**Contact VACUUBRAND customer service if the motor protection is triggered:**

[www.vacuubrand.com/service](http://www.vacuubrand.com/service)

[service@vacuubrand.com](mailto:service@vacuubrand.com)

Tel.: +49 9342 808 5660

## **Shutdown**

### **NOTICE**

#### **Short-term:**

Has the pump been exposed to condensate?

- Allow the pump to continue to run at atmospheric pressure for a few minutes.

Has the pump been exposed to media which may damage the pump materials or form **deposits**?

- Check and clean pump heads if necessary.

#### **Long-term:**

- Take measures as described in section short-term shutdown.

- Separate pump from the apparatus.

- Close inlet and outlet port (e. g. with transport caps).

- Close the gas ballast valve.

- Store the pump in dry condition

## Circuit diagram

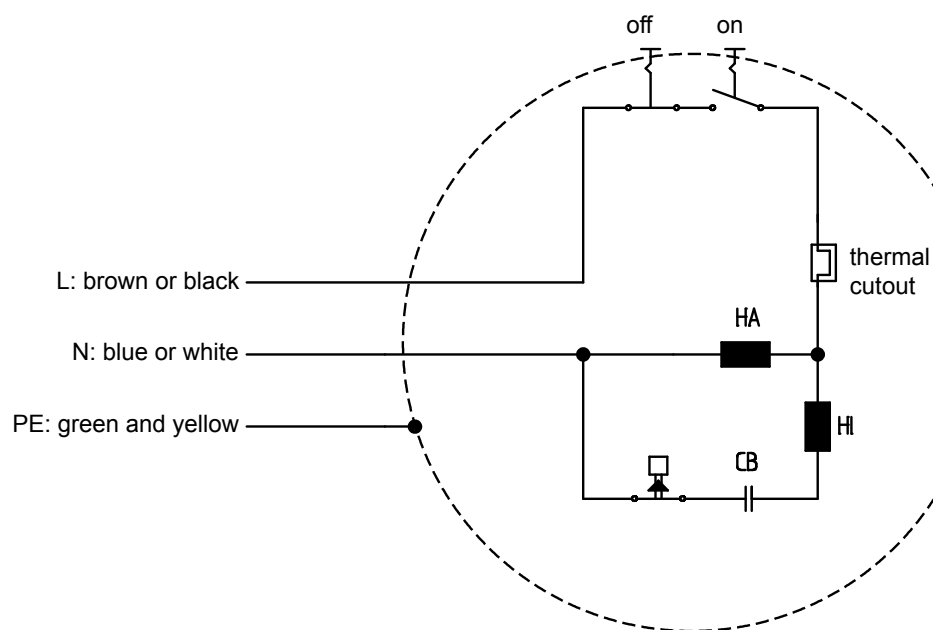

### Motor cable

Cable diameter: 9.2 mm - 11.9 mm

Cable type: H07RN-F-255-3G

Wire size: 1.5 mm<sup>2</sup>

## Troubleshooting

**Never operate a defective pump!  
Read and obey the instructions for use!**

Fault	Possible cause	Remedy
<input type="checkbox"/> Pump does not start or stops immediately.	<ul style="list-style-type: none"> <li>➔ Mains not plugged in, electrical supply failure?</li> <li>➔ Pressure in outlet pipeline too high?</li> <li>➔ Motor overloaded?</li> </ul>	<ul style="list-style-type: none"> <li>✓ Check power supply and fuse in the building installation.</li> <li>✓ Remove blockade in line, open valve.</li> <li>✓ Contact VACUUBRAND customer service.</li> </ul>
<input type="checkbox"/> Pump does not achieve its ultimate vacuum or usual pumping speed.	<ul style="list-style-type: none"> <li>➔ Centring ring at small flange connection not correctly positioned or leak in the pipeline or vacuum system?</li> <li>➔ Long, narrow line?</li> <li>➔ Pump has been exposed to condensate?</li> <li>➔ Deposits have been formed inside the pump?</li> <li>➔ Diaphragms or valves damaged?</li> <li>➔ Outgassing substances or vapour generated in the process?</li> </ul>	<ul style="list-style-type: none"> <li>✓ Check pump directly - connect vacuum gauge directly at pump inlet - then check connection, pipeline and vacuum system if necessary.</li> <li>✓ Use lines with larger diameter, length as short as possible.</li> <li>✓ Allow pump to run for some minutes with atmospheric pressure at the inlet.</li> <li>✓ Clean and inspect the pump heads.</li> <li>✓ Replace diaphragms and/or valves.</li> <li>✓ Check process parameters.</li> </ul>
<input type="checkbox"/> Pump too noisy. <b>Attention: Switch off pump immediately and inspect!</b>	<ul style="list-style-type: none"> <li>➔ Loud exhaust noise?</li> <li>➔ Diaphragm crack or diaphragm clamping disc loose?</li> <li>➔ Motor bearing defective?</li> <li>➔ Deposits have been formed inside the pump?</li> <li>➔ Diaphragms or valves defective?</li> <li>➔ Other than above mentioned causes?</li> </ul>	<ul style="list-style-type: none"> <li>✓ Connect hose or silencer to pump outlet.</li> <li>✓ Perform maintenance.</li> <li>✓ Contact local distributor.</li> <li>✓ Clean and inspect pump heads.</li> <li>✓ Replace diaphragms and/or valves.</li> <li>✓ Contact local distributor.</li> </ul>
<input type="checkbox"/> Pump seized.		<ul style="list-style-type: none"> <li>✓ Contact local distributor.</li> </ul>

## Maintenance of the diaphragm pump

Diaphragm pumps with ATEX compliance can be sent to the VACUUBRAND factory for maintenance, or VACUUBRAND technicians can perform maintenance on site.

### **IMPORTANT**

When performing maintenance on diaphragm pumps with ATEX compliance, the operator must observe the following:

Maintenance work on ATEX-compliant diaphragm pumps may only be performed qualified, competent, and trained personnel.

We recommend training by VACUUBRAND, which covers the specific maintenance requirements and the use of the „ATEX pump head clearance measuring device”.

Maintenance of the diaphragm pump, the special „ATEX pump head clearance measuring device” required for this purpose, tools and spare parts are described in a separate maintenance manual.

Information on maintaining the ATEX diaphragm pump is available at:

[www.vacuubrand.com/service](http://www.vacuubrand.com/service)

[service@vacuubrand.com](mailto:service@vacuubrand.com)

Tel.: +49 9342 808 5660

### Spare parts

Diaphragm head clearance measuring device .....	<b>20680000</b>
Set of seals (diaphragms, valves, O-rings, sealing bond (PTFE))	
MZ 2C EX / MZ 2C EX + AK + EK.....	<b>1 x 20696837</b>
MD 4C EX / MD 4C EX + AK + EK.....	<b>2 x 20696837</b>
MV 10C EX / MV 10C EX + AK + EK .....	<b>4 x 20696837</b>
Valve (one piece).....	<b>20637225</b>
(internal overpressure valve in MD 4C EX, MD 4C EX + AK + EK, MV 10C EX, MV 10C EX + AK + EK)	

## Inspecting the overpressure safety valve

### Inspecting the overpressure safety valve at the outlet:

- ➔ Unscrew the overpressure safety valve at the outlet of the pump.

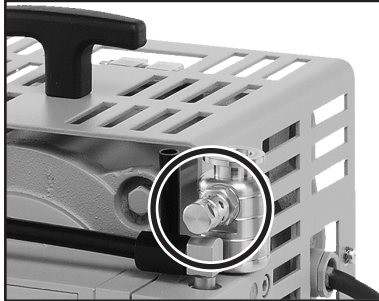

MZ 2C EX

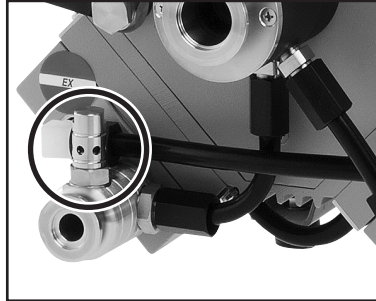

MD 4C EX

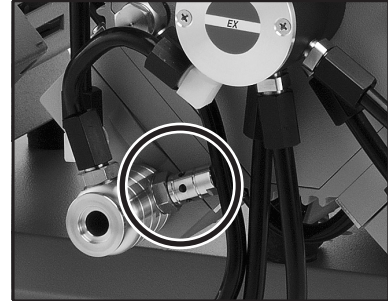

MV 10C EX

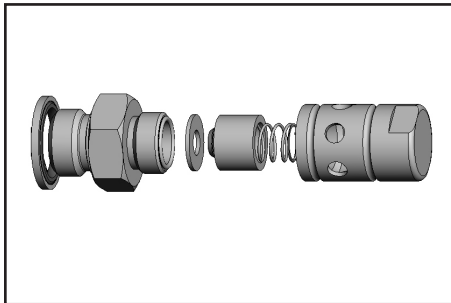

- ➔ Disassemble the overpressure safety valve and inspect the parts for faultless condition, replace damaged parts.
- ➔ Reassemble the valve correctly.
- ➔ Screw the overpressure safety valve to the outlet of the pump.

### Spare parts

Flat seal (overpressure safety valve at the outlet).....	<b>20637081</b>
Spring (overpressure safety valve at the outlet).....	<b>20637065</b>

## Repair - Maintenance - Return - Calibration

### **IMPORTANT**

Every employer (user) is held responsible for the health and safety of his employees. This also applies to service personnel performing repair, maintenance, return or calibration.

The **health and safety clearance form** informs the contractor about any possible contamination of the device and forms the basis for the risk assessment.

**In case of devices which have been in contact with biological substances of risk level 2 contact the VACUUBRAND service absolutely before dispatching the device. These devices have to be completely disassembled and decontaminated by the user prior to shipment. Do not return devices which have been in contact biological substances of risk level 3 or 4.** These devices cannot be checked, maintained or repaired. Also decontaminated devices must not returned to VACUUBRAND due to a residual risk.

The same conditions apply to on-site work.

**No repair, maintenance, return or calibration is possible unless the correctly completed health and safety clearance form is returned. Devices sent are rejected if applicable.** Send a completed copy of the health and safety clearance form to us in advance. The declaration must arrive before the equipment. Enclose a second completed copy with the product.

Remove all components from the device that are no original VACUUBRAND components. VACUUBRAND will not be responsible for lost or damaged components that are no original components.

**Drain the device completely of fluids and residues. Decontaminate the device.** Close all openings airtight especially if using substances hazardous to health.

To expedite repair and to reduce costs, please enclose a detailed description of the problem and the product's operating conditions with every product returned.

If you do not wish a repair on the basis of our **quotation**, the device may be returned to you disassembled and at your expense.

In many cases, the components must be cleaned in the factory prior to repair.

For cleaning we use an environmentally friendly water based process. Unfortunately the combined attack of elevated temperature, cleaning agent, ultrasonic treatment and mechanical stress (from pressurised water) may result in damage to the paint. Please mark in the health and safety clearance form if you wish a repaint at your expense just in case such a damage should occur. We will also replace parts for cosmetic reasons at your request and at your expense.

#### **Before returning the device**

Pack the device properly, if necessary, please order original packaging materials at your costs.

Mark the package completely.

**Enclose the completed [health and safety clearance form](#).**

Notify the carrier of any possible contamination if required.



#### **Scrapping and waste disposal**

Dispose of the equipment and any components removed from it safely in accordance with all local and national safety and environmental requirements. Particular care must be taken with components and waste oil which have been contaminated with dangerous substances from your processes. Do not incinerate fluoroelastomer seals and O-rings. You may authorize us to dispose of the equipment **at your expense**. Otherwise we return the device at your expense.

**INSTRUCTIONS MANUAL: EXPLOSION PROOF INDUCTION MOTORS**

**Contents**

INTRODUCTION .....2  
GENERAL CHARACTERISTICS .....2  
MOTOR MARKINGS .....3  
USE OF MOTORS .....4  
INCOMING INSPECTION .....4  
STORAGE .....5  
SAFETY CONSIDERATIONS .....5  
MOUNTING AND START UP .....5  
MOTOR PROTECTION .....7  
OPERATING CONDITIONS .....7  
BALL BEARINGS .....7  
MAINTENANCE .....7  
REPAIR .....7  
SPARE PARTS .....8  
CONDITIONS OF USE .....9  
APPLICABLE STANDARDS .....10  
MANUFACTURER INFORMATION: .....10

## ELNOR MOTORS NV

**INTRODUCTION**

An explosion-proof, and in particular a flameproof motor, is one that is inherently safe when working in potentially explosive atmospheres.

This means that its construction and assembly are designed so that ingress of explosive gases or dusts is rendered harmless for the environment.

In the event of accidental ignition, provoking an explosion inside the motor housing, the motor shell and brackets are strong enough to resist the internal pressure created by this explosion.

Moreover, assembly joints and shaft clearance must be long enough and offer minimum play, so that hot gases or dusts resulting from an explosion will be cooled sufficiently to create no possibility of an explosion outside the motor.

The outside temperature of the motor enclosure must also be kept well below the flash point of the gases or dusts present in the hazardous atmosphere, both in normal and abnormal working conditions.

Finally, it is the manufacturer's concern that components inside the motor should be able to withstand an occasional explosion without being adversely affected.

**⚠** As explosion proof motors are constructed with special materials and technologies that comply with the legal regulations concerning potentially explosive atmospheres, a wrong connection or a minor modification of the motor destroys the compliance with security regulations. The rules concerning explosion proof apparatus must be observed unconditionally. Note that our motors are approved for a specific group of hazardous areas and temperature classes.

If you are unclear about information's given in this documentation, or if you require further information, please contact Elnor Motors.

**GENERAL CHARACTERISTICS**

Flame proof induction motor for explosive atmosphere.

Motor prefix	Motor Type	Max. Voltage (VAC)	Frequency (Hz)	Max. power (kW)
BA	3xy***	690	50,60 or 50/60	2,2
BAX	2xy***	400	50,60 or 50/60	0,35
or	1xy***	415	50,60 or 50/60	1
BAV	1xy***H2	415	50,60 or 50/60	1
	73xy***	690	50,60 or 50/60	0,55

BA – naturally cooled explosion proof motor;

BAV – fan cooled explosion proof motor;

BAX - explosion proof motor cooled by application;

xy – length of the stator stack, if length less than 100 mm;

\*\*\* - TR – three phase motor;

- C – single phase motor with start capacitor;

- E – single phase motor with permanent run-capacitor;

- CP – single phase motors with start and permanent-run capacitor;

Outside dimensions:

Since our motors are custom made, the outside dimensions, the motor foot/plate, the shaft and the motor face are particular to each customer, please refer to the general drawing attached to your offer.

## ELNOR MOTORS NV

**MOTOR MARKINGS**

## Product Marking

The equipment will be marked with the information shown below. Actual layout may vary depending on whether the equipment is single marked or multi marked (ie. ATEX, UKEX, IECEx, INMETRO).

ELNOR MOTORS N.V. B-3150 Haacht Belgium	Company name and address
AB xx ATEX yyy X	AB – name of the notified body issuing the EU type certificate; xx – year of issue of certificate; yyyy- number of EU type certificate; X – special conditions of use;
IECEx AB x x.yyyy X	AB – name of the certified body issuing the IECEx certificate; xx – year of issue of certificate; yyyy- number of Ex certificate; X – special conditions of use;
AB xx UKEX yyyy X	AB – name of the approved body issuing the UKEX certificate; xx – year of issue of certificate; yyyy- number of the UKEX certificate; X – special conditions of use;
II2 G	Equipment group II – non-mining; Equipment category 2 – high protection (see table1); Ignition source risk G –gas;
Exdb IIB	Protection concept Ex d – flameproof enclosure Gas group IIB – Ethylene (for a complete list of gases in this category please refer to standard IEC60079-20-1)
Exdb IIC	Protection concept Ex d – flameproof enclosure Gas group IIC – typical gases are hydrogen and acetylene (for a complete list of gases in this category please refer to standard IEC60079-20-1)
IIB+H2	Gas group IIB+H2 (for a complete list of gases in this category please refer to standard IEC60079-20-1)
Tx	Maximum surface temperature T3, T4, T5 or T6 (see table2)
Gb	Equipment protection level Gb – zone 1(see table1)
Tamb –xx°C to +xx°C	Ambient temperature from minimum -40°C to maximum +70°C, depending on the motor type and protection type.
xxV	Nominal voltage
RPM xxxx	Nominal speed
xx A	Nominal current
P = xxx W	Nominal power
Sx	Service class
CL F	Thermal class
N° JJWW/NFNF xxx	Serial number where: JJ – last 2 digits of the year; WW – number of the week; NFNF – fabrication number; xxx – batch order number;
Customer Ref.	Customer reference if needed;

## USE OF MOTORS

**⚠** The ELNOR motor is intended for industrial use only. The motor should not be used until the machine in which it is to be installed had met all the necessary approval and regulations. Before installation, the user must check if the group and protection class, marked on the motor label, corresponds with the requested conditions.

ZONES AND EQUIPMENT CATEGORIES				
Zones <sup>1)</sup> <sup>2)</sup>	Broad definitions of the zones ( for guidance only) IEC/EN 60079-10-1	Equipment category 2014/34/EU	Equipment protection level IEC/EN 60079-0	Equipment integrity requirements
1	An area in which it is expected that an explosive gas atmosphere will occur occasionally during normal operation.	2	Gb	Equipment must be safe under normal operation, expected malfunction.

**Table 1 zones and equipment categories**

**⚠** Under no circumstances may Elnor motors be used in zone0

1) - Motors of- Zone 1 can also be used in Zone 2

2) - Motors which are certified for gas must not be used in dust or in hybrid mixtures! Hybrid mixtures: when explosive gas and dust atmospheres occur simultaneously.

TEMPERATURE CLASS	
T CLASS	MAXIMUM SURFACE TEMPERATURE
T1	450°C
T2	300°C
T3	200°C
T4	135°C
T5	100°C
T6	85°C

**Table 2 - Temperature class**

Temperature classification of the motor depends on the internal thermal protection and it is given on the name plate.

**⚠** Under no circumstances should a lower temperature class be used to replace a higher temperature class motor (ie. T3 should not replace a T6).

## INCOMING INSPECTION

When receiving the motors, check if any damage has occurred to the packaging of the motors during transportation. If so, immediately notify the carrier, the insurance company and supplier. Failure to do so may invalidate any possible claims.

Inspect the following after packaging has been removed:

- Check for any damage to the motor;
- Check nameplate data to ensure correct motor has been received;
- Check if dimensions and colour are in compliance with your specifications;
- Rotate the shaft by hand to make sure it is turning freely;
- Make sure the motor was not exposed to excessive dirt and moisture during transportation and storage.

In the unlikely event of a claim, please contact our Sales Office.

**⚠** Do not use the motor when damaged.

## STORAGE

The motor should be stored in a clean, dry and vibrations free environment. If the motor is to be stored for a long period of time, the shaft protected with anti-rust coating should be checked and "touched up" if necessary.

## SAFETY CONSIDERATIONS

 Electric motors are source of electrical hazards and consequently their improper use may cause injury and/or damage to people, animals and objects.

Only properly qualified personnel are permitted to perform such tasks as transport, assembly, commissioning and maintenance. The qualified personnel must know and observe all relevant safety standards.





The motor may not be opened in the presence of potentially explosive atmospheres, or when energized.

## MOUNTING AND START UP

Electric data of the motor, valid for the rated power, can be found on the nameplate.

It is the responsibility of the user to ensure that the motor nameplate voltage and frequency are the same as the mains supply.

 The user has to ensure that the earth connection is properly made. The grounding connectors are provided inside the terminal box and on the motor frame. According to IEC 60079-0, the grounding cable must have a cross section area of at least 4 mm<sup>2</sup>. Always ensure compliance with local regulations and demands.

  Connection to the mains supply should only be executed by a recognised professional, respecting local demands and regulations.

If motors are supplied without cable the user must ensure that the diameter of the cable is adequate for the voltage and current involved. (See nameplate data of motor)

The connection of the wires must be done as described in the connection diagram that is delivered with the motor. The connection diagram is usually located inside the cover of the terminal box.

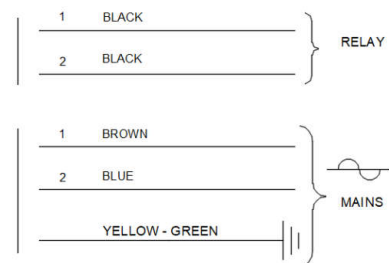

The connection diagram is structured as follows: (see example)

The leads can be coloured, numbered or both. Each line represents one lead. The given connection diagram is an example only.

An indication of the tightening torques for the electric connections is give in table bellow:

Thread size	M4	M5	M6
Torque (Nm)	1,5	2	3

Table 3. Tightening torques for electrical connections

The motor must be protected against overloads and short-circuits, through the use of a fuse that corresponds to the current draw as indicated on the nameplate.

## ELNOR MOTORS NV

Since our motors are custom made, speed and torque curve are also specific for each motor type and they should be requested from the manufacturer.

The manufacturer cannot be held responsible for damage due to incorrect installation or use.

Free circulation of fresh air for cooling the motor must be guaranteed

The maximum ambient temperature must not exceed the given value that is indicated on the nameplate and in the motor certificate.

To guarantee the explosion proof protection, certified explosion proof cable glands with sealing joints adapted to the cable diameters, must be used in compliance with IEC 60079-0 and IEC 60079-1.

If cable glands are provided with the motor, the cable diameter range as indicated in the attached document, has to be respected. The supplied cable glands are suitable for non-shielded cables only. The cable must be chosen to withstand the maximum cable temperature, as indicated on the nameplate.

**⚠ THE MOTOR WILL LOSE ITS EXPLOSION PROOF CHARACTERISTICS IF THE CABLE AND GLANDS ARE NOT FITTED CORRECTLY!**

Note: If a spare opening for a cable gland isn't used, only the use of cable glands or blanking elements rated Ex db IIB Tx Gb - where Tx is the temperature class of the motor, as given on the name plate - suitable for use in an ambient of  $-40^{\circ}\text{C} \leq T_{\text{amb}} \leq +70^{\circ}\text{C}$ , minimum, in compliance with IEC 60079-0 and IEC 60079-1, retains the explosion proof characteristics.

Particular attention is to be given to the fixing torque of bolts and screws. The motor fixing bolts are factory mounted with the correct torque and should not be touched.

It may be necessary to open the terminal box for connecting the motor. When re-mounting the cover, only use the original screws. The fastening torque for the bolts is given in the table below:

Bolt thread size	M5	M6	M8
Torque (Nm)	4 - 5	7 - 9	12 - 14

Table 4. Fastening torque for bolts

- ⚠ Firstly tighten all bolts by hand before applying the full torque. If 4 bolts are present, firstly tighten two diametrically opposed bolts and then the other two.
- ⚠ Motors without a terminal box as all motors in range BA(X)2xx and some motors in range BA(X, V)3xx may not be opened. If opened motors will lose their explosion proof characteristics.
- ⚠ When the threaded blind holes provided on the motor flange are used, only appropriate bolts or screws should be used. The size of the thread engagement, diameter and maximum length, is provided on the customer specific drawing. Under no circumstances should a longer thread engagement be used.

#### *Using a pulley or a coupling device:*

Apply only well-balanced discs and couplings. Check the alignment after assembling  
Take care while mounting of the pulley on the shaft: Hammering on the shaft will damage the motor bearings. Pulleys should only be mounted with appropriate mounting tools that do not stress the motor bearings.

Following these recommendations will greatly increase the expected motor bearing life.

Safety regulations in respect of guarding couplings and belts from being accidentally touched must be applied.

## ELNOR MOTORS NV

Motor type	Diameter (mm)	Length for $F_R$ (mm)	$F_R(N)$ - max		$F_A (N)$ -max
			Cast iron end shield	Aluminium end shield	
BA73xx	11	30		NA	100
BA1xx	14	30	600	NA	150
BA2xx	14	11	NA	1000	140
BA3xx	20	100	600	300	200

Table 5. Permissible forces on shaft

- ⚠  $F_R$  is computed assuming no axial force is present and in normal conditions of use;
- ⚠  $F_A$  is computed assuming no radial force is present;
- ⚠ Since our motors are custom made it is impossible to list in the manual all the different shaft/end shield configurations. If your configuration is not present in the above table please ask the motor manufacturer.

## MOTOR PROTECTION

Each motor is provided with an internal thermal protection. If the motor is supplied with a thermal protection, Thermik S06.135 or similar, that is brought out separately, the user must connect the protection in a way that the motor is switched off when the protector switches and doesn't start until an operator starts it manually.

## OPERATING CONDITIONS

In general our electric motors are designed for operation up to an altitude of 1000m above sea level and an ambient temperature between -20°C and +40°C. Any variation is stated on the nameplate. Voltage variation may not exceed  $\pm 10\%$ . Motors should be kept dust free to allow heat exchange to occur.

## BALL BEARINGS

The life of the ball bearings and radial and axial forces are motor specific, contact the motor manufacturer for information over life expectancy of ball bearing for your particular application. The maximum operating temperature of the ball bearings is 150C.

## MAINTENANCE

Re-greasing of the motor bearings is not necessary, the ball bearing are lubricated for life. Dust build-up on the motor must be avoided.

If the noise level is enhanced, switch off the motor immediately and inspect. Replacement of the bearings must only be performed at the manufacturer.

- ⚠ Unless agreed in writing maintenance action are to be done only by the manufacturer.

## REPAIR

The explosion proof motor may not be opened while the motor is energised.

- ⚠ Unless agreed in writing repairs are to be done only by the manufacturer.

ELNOR MOTORS NV

**Warning:**

 The flameproof joints are not intended to be repaired or reworked by the user.

 The manufacturer is not responsible for motors that are modified or opened without his written agreement.

**END OF LIFE**

Dismantling of the motor should be done only by qualified personnel following the local safety regulations in place.

Motor contains iron, aluminium, copper and plastic parts which should be recycled by an approved recycling company at the end of life.

**SPARE PARTS**

For each order of spare parts, the type and number of the motor must be given; these data are indicated on the nameplate.

ELNOR MOTORS NV

**CONDITIONS OF USE**

Motor prefix      Motor Type      Specific conditions

3xy\*\*\*

**ATEX and UKEX**

1. An appropriate connection of the free end of the cable shall be foreseen in case the motor is provided with a permanently connected cable.
2. If operated with a frequency drive, or when a temperature class better than a T3 has to be respected a thermal protection device has to be installed. The following table details the maximum set points of the thermal protection device per temperature class:

Temperature class	Set point windings	Set point end shields/bearings
T3	150	135
T4	135	120

**IECEX**

1. The flameproof joints are not intended to be repaired.
2. The property class of the special fasteners used to fasten the end shields onto the stator housing

Property class	Part of the special fastener
4.6	Hexagon cap screws
5	Hexagon nut (if used)
8.8	Socket cap screws

3. Model BAV : The motor may be equipped with one or two end shaft(s) or with an external fan. For the fan cooled motors in BAV construction, the motor fan is intended for cooling the motor.
4. Model BAX : When the motor is used to drive a fan, the new assembly, fan and motor unit, requires separate certification.

BA  
BAX  
BAV

2xy\*\*\*

**ATEX UKEX IECEX**

1. Temperature classification of motors is as follows:

Thermal protection location	Switch off thermal protection in C	Temperature at the entry point cable in C	Temperature Class
Winding	135	75	T4
	150	84	T3

2. All safety devices shall operate independently of any measurement or control devices required for operation.
3. No modification must be made to the flamepaths of the enclosure without prior consultation with the manufacturer.

1xy\*\*\*

1. the property class of the special fasteners used to fasten the end shields onto the stator housing must be at least:8,8;
2. BAX - When the motor is used to drive a fan, the new assembly, fan and motor unit, requires separate certification;
3. Optional push buttons can be installed in the wall of the enclosure;

1xy\*\*\*H2

1. the property class of the special fasteners used to fasten the end shields onto the stator housing must be at least 12.9;
2. BAX - When the motor is used to drive a fan, the new assembly, fan and motor unit, requires separate certification;

73xy\*\*\*

1. An appropriate connection of the free end of the cable shall be foreseen when the motor is provided with a cable permanently connected to it;
2. The flamepaths are specified in the manufacturer drawing;

## ELNOR MOTORS NV

**APPLICABLE STANDARDS**

IECEX/IEC	ATEX	UKCA	
IEC 60204-1:2016	EN 60204-1:2018	BS EN 60204-1:2018	Safety of machinery – Electrical equipment of machines – Part 1: General requirements
IEC 60034-1:2017	EN 60034-1:2010	BS EN 60034-1:2010	Rotating electrical machines – Part 1: Rating and performance
IEC 60079-0:2017	EN IEC 60079-0:2018	BS EN IEC 60079-0:2018	Explosive Atmospheres – Part 0: Equipment – General requirements
IEC 60079-1:2014	EN 60079-1:2014	BS EN 60079-1:2014	Explosive Atmospheres – Part 1: Equipment – Equipment protection by flameproof enclosures "d"
	EN 50581:2012	BS EN 50581:2012	Technical documentation for the assessment of electrical and electronic products with respect to the restriction of hazardous substances
	Directives 2014/34/EU		European ATEX Product Directive
		SI 2016 No. 1107 amended by SI2019 No.696	HEALTH AND SAFETY The Equipment and Protective Systems Intended for Use in Potentially Explosive Atmospheres

**MANUFACTURER INFORMATION:**

ELNOR MOTORS NV  
De Costerstraat 45  
B-3150 HAACHT  
BELGIUM

Telephone: +32 16 60 13 94  
Fax: +32 16 60 64 40  
E-mail: [info@elnor.be](mailto:info@elnor.be)  
Internet: <http://www.elnor.be>

This document has been made with the greatest care and is correct at the time of printing. It is meant as a general guideline and it is not meant to be complete. Always check with relevant regulations and guidelines.

**Certificate for motors with mark „II 2G Ex db IIB T4 Gb“**



**APRAGAZ**  
a.s.b.l.  
Your inspecting authority



- (1) **EU TYPE EXAMINATION CERTIFICATE**
- (2) **Equipment or Protective system intended for use  
in potentially explosive atmospheres  
Directive 2014/34/EU**
- (3) EU type examination certificate number: **APRAGAZ 20ATEX0209 X**
- (4) Equipment or protective system: Three-phase and single-phase asynchronous motors  
Single-phase: BA(V or X) 3xy C or E or CP  
Three-phase: BA(V or X) 3xy TR
- (5) Applicant - Manufacturer: Elnor Motors NV Belgium
- (6) Address: De Costerstraat 45  
3150 Haacht (Wespelaar)  
Belgium
- (7) This equipment or protective system and any acceptable variation thereto is specified in the schedule to this certificate and the documents therein referred to.
- (8) APRAGAZ, notified body n° 0029 in accordance with article 17 of the directive 2014/34/EU of 26 February 2014, certifies that this equipment or protective system has been found in compliance with the essential health and safety requirements relating to the design and construction of equipment and protective systems intended for use in potentially explosive atmospheres, given in annexe II of the directive.
- The examination and test results are recorded in the confidential file n° 17566/006.
- (9) The conformity of the essential health and safety requirements has been assured by compliance with:  
EN 60079-0: 2018  
EN 60079-1: 2014
- (10) If the sign “X” is placed after the certificate number, it indicates that the equipment or protective system is subject to special conditions for safe use specified in the schedule to this certificate.
- (11) This EU TYPE EXAMINATION CERTIFICATE relates only to the design and construction of this specified equipment or protective system in accordance with the directive 2014/34/EU. Further requirements of the directive apply to the manufacturing and supply of this equipment or protective system. These are not covered in this certificate.
- (12) The marking of the equipment or protective system shall include the following:  
⊕ II 2 G Ex db IIB T4...T3 Gb

Brussels, 07 December 2020

APRAGAZ  
Chaussée de Vilvorde 156  
1120 Bruxelles  
tel 02/264 03 60 fax 02/268 89 58  
mail : info@apragaz.com

Ir. B. Nève  
General Manager

This certificate can only be reproduced in his entirety, schedule included, without any modification

Rev. 0

1/3

R.A. 001 rev2 – 08-2020



**APRAGAZ**  
a.s.b.l.  
Your inspecting authority



- (13) **SCHEDULE**
- (14) **EU TYPE EXAMINATION CERTIFICATE N° APRAGAZ 20ATEX0209 X**
- (15) Description of the equipment or protective system

Three-phase and single-phase asynchronous motors:  
Single-phase: BA(V or X) 3xy C or E or CP  
Three-phase: BA(V or X) 3xy TR

BA: a naturally cooled explosion proof motor  
BAV: a fan cooled explosion proof motor  
BAX: a motor cooled by the application

The motor consists of a flameproof enclosure which is made of an aluminium or a steel sheet metal carcass and has aluminium or cast iron end shields.

The fastenings are made by hex cap screw of property class 4.6, nuts of property class 5.0 and socket cap screws of property class 8.8.

The motor may be equipped with two ends shafts and can be electrically directly fed by a single cable or through a connection in the terminal box.

#### Temperature classes

The motors on S1 duty service cooled by the process have the temperature class T3. The motors have a temperature class T4 if they are equipped with a thermal protection suitable to the temperature class. The motors with natural cooling, the motors energized by converters and the motors on S2 to S9 duty service are provided with a direct thermal protection or a PTC resistance suitable to the temperature class.

#### Electrical characteristics

Power range: from 0,25 kW to 2,5 kW  
Voltage supply: up to 690 Volt – For VAC motors: 50/60 Hz  
Insulation class: F

#### Routine tests

The manufacturer shall make the routine verifications and tests necessary to ensure that the electrical apparatus produced complies with the specifications submitted to the testing station together with the prototype or sample.

Every part of the motor legible for routine testing whether it's made from aluminium, iron cast or steel that is tested at 4\*Pref is exempted from overpressure pressure testing, otherwise the routine tests at 11,01 bar need to be executed.

The control of the weld of the steel carcass is always to be tested at 11,01 bar.

A motor of every fabrication number is additionally tested on the test bench. This to verify the maximum surface temperatures on different parts on the motor for the specific type of motor.

Cables resisting up to 120°C should be selected for a T3 and cables resisting up to 100°C should be selected for a T4 motor.



This certificate can only be reproduced in his entirety, schedule included, without any modification

Rev. 0

2/3

R.A. 001 rev2 – 08-2020



**APRAGAZ**  
a.s.b.l.  
Your inspecting authority



- (13) **SCHEDULE**
- (14) **EU TYPE EXAMINATION CERTIFICATE N° APRAGAZ 20ATEX0209 X**

(15) Marking:

Elnor Motors NV Belgium  
De Costerstraat 45  
3150 Haacht (Wespelaar)  
Belgium

Year CE + Identification n° of NOBO production control phase  
Type: BA(X/V) 3xy  
Serial number: 650xxxxx  
Manufacturer date, fabrication number and batch number : JJWW/NFNF xxx



II 2 G Ex db IIB T4...T3 Gb  
APRAGAZ 20ATEX0209 X

Warning:

Do not open under voltage.

Eventual prescriptions

Choice of cable needs to be compatible with a temperature of X °C.  
Ambient temperature range: -40°C up to +70°C.  
An adequate warning is to be printed when the motor is delivered without cable glands, plugs or cable.

Note:

This X °C is in function of the temperature class of the motor. X=120°C for a T3 motor and X=100°C for a T4 motor.  
Depending on the foreseen duty class of the motor the temperature range can be narrowed.

- (16) The examination and test results are recorded in confidential report n° U194718.

(17) Special conditions for safe use:

An appropriate connection of the free end of the cable shall be foreseen in case the motor is provided with a permanently connected cable.

If operated with a frequency drive, or when a temperature class better than a T3 has to be respected a thermal protection device has to be installed directly in the motor. The following table details the maximum set points of the direct thermal protection device per temperature class:

Temperature class	Set point windings in °C	Set point end shields/bearings in C°
T3	150	135
T4	135	120

(18) Essential health and safety requirements:

The essential health and safety requirements are covered by the conformity to European standards listed at (9).



# EG-Konformitätserklärung EC Declaration of Conformity Déclaration CE de conformité



Hersteller / Manufacturer / Fabricant:

**VACUUBRAND GMBH + CO KG** · Alfred-Zippe-Str. 4 · 97877 Wertheim · Germany

Hiermit erklärt der Hersteller, dass das Gerät konform ist mit den Bestimmungen der Richtlinien:

Hereby the manufacturer declares that the device is in conformity with the directives:

Par la présente, le fabricant déclare, que le dispositif est conforme aux directives:

- 2014/34/EU
- 2011/65/EU, 2015/863
- 2006/42/EG (gilt nur für Motor / applies only for motor / ne s'applique qu'au moteur)

Membranvakuumpumpe / Diaphragm vacuum pump / Pompe à membrane:

Typ / Type / Type: MZ 2C EX / MZ 2C EX + AK + EK / MD 4C EX / MD 4C EX + AK + EK / MV 10C EX / MV 10C EX + AK + EK

Artikelnummer / Order number / Numéro d'article: 20696920 / 20696921 / 20696922 / 20696930 / 20696931 / 20696932 / 20696945 / 22614250

Seriennummer / Serial number / Numéro de série: Siehe Typenschild / See rating plate / Voir plaque signalétique

Angewandte harmonisierte Normen / Harmonized standards applied / Normes harmonisées utilisées:

EN 1127-1:2019, EN ISO 80079-36:2016 (ISO 80079-36:2016), EN IEC 63000:2018 (IEC 63000:2016)

Motor / motor / moteur: EN 60204-1:2018 (IEC 60204-1:2016), EN IEC 60079-0:2018 (IEC 60079-0:2017), EN 60079-1:2014 (IEC 60079-1:2014)

Bevollmächtigter für die Zusammenstellung der technischen Unterlagen / Person authorised to compile the technical file /  
Personne autorisée à constituer le dossier technique:

Dr. Constantin Schöler · VACUUBRAND GMBH + CO KG · Germany

Die technische Dokumentation gemäß der Richtlinie 2014/34/EU (ATEX) wird im Auftrag von VACUUBRAND GMBH + CO KG bei der entsprechend beauftragten Hinterlegungsstelle hinterlegt:

The technical documentation in accordance with directive 2014/34/EU (ATEX) is deposited on behalf of VACUUBRAND GMBH + CO KG with the relevant authorized depository:

La documentation technique conformément à la directive 2014/34/EU (ATEX) est déposée au nom de VACUUBRAND GMBH + CO KG auprès de l'institution de dépôt mandatée à cet effet:

IBEXU Institut für Sicherheitstechnik GmbH · Fuchsmühlenweg 7 · 09599 Freiberg · Germany

Ort, Datum / place, date / lieu, date: Wertheim, 24.06.2025

(Dr. Constantin Schöler)

*Geschäftsführer / Managing Director / Gérant*

ppa.

*Technischer Leiter / Technical Director /  
Directeur technique*

**VACUUBRAND GMBH + CO KG**

Alfred-Zippe-Str. 4  
97877 Wertheim

Tel.: +49 9342 808-0  
Fax: +49 9342 808-5555  
E-Mail: [info@vacuubrand.com](mailto:info@vacuubrand.com)  
Web: [www.vacuubrand.com](http://www.vacuubrand.com)

**VACUUBRAND®**

**Einbauerklärung für Maschinen**  
**Declaration of Incorporation of the Machinery**  
**Déclaration d'incorporation des machines**

Hersteller / Manufacturer / Fabricant:

**VACUUBRAND GMBH + CO KG** · Alfred-Zippe-Str. 4 · 97877 Wertheim · Germany

Hiermit erklärt der Hersteller, dass die unvollständige Maschine konform ist mit den Bestimmungen der Richtlinie:

Hereby the manufacturer declares that the incomplete machinery is in conformity with the directive:

Par la présente, le fabricant déclare, que la quasi-machine est conforme à directive:

- 2006/42/EG

Membranvakuumpumpe / Diaphragm vacuum pump / Pompe à membrane:

Typ / Type / Type: MZ 2C EX / MZ 2C EX + AK + EK / MD 4C EX / MD 4C EX + AK + EK / MV 10C EX / MV 10C EX + AK + EK

Artikelnummer / Order number / Numéro d'article: 20696920 / 20696921 / 20696922 / 20696930 / 20696931 / 20696932 / 20696945 / 22614250

Seriennummer / Serial number / Numéro de série: Siehe Typenschild / See rating plate / Voir plaque signalétique

Angewandte harmonisierte Normen / Harmonized standards applied / Normes harmonisées utilisées:

EN ISO 12100:2010 (ISO 12100:2010), EN 1012-2:1996 + A1:2009

Weitere angewandte Normen / Other standards applied / Autres normes utilisées:

EN 61010-1:2010 + A1:2019 + A1:2019/AC:2019 (IEC 61010-1:2010 + COR:2011 + A1:2016, modifiziert / modified / modifié + A1:2016/COR1:2019)

Die technische Dokumentation nach Anhang VII B wurde erstellt. Der Hersteller verpflichtet sich, die technische Dokumentation zur unvollständigen Maschine den zuständigen Stellen in Papierform auf Verlangen zu übermitteln.

The technical documentation in accordance with annex VII B has been compiled. The manufacturer undertakes to submit the technical documentation relating to the incomplete machine to the relevant national authorities as paper mold on request. La documentation technique selon l'annexe VII B a été établie. Le fabricant s'engage à remettre la documentation technique concernant la quasi-machine aux services compétents sous forme papier à leur demande.

Bevollmächtigter für die Zusammenstellung der technischen Unterlagen / Person authorised to compile the technical file / Personne autorisée à constituer le dossier technique:

Dr. Constantin Schöler · VACUUBRAND GMBH + CO KG · Germany

Die Inbetriebnahme dieser unvollständigen Maschine ist so lange untersagt, bis festgestellt wurde, dass die Maschine, in die sie eingebaut werden soll, den Bestimmungen der EG-Richtlinie Maschinen, den harmonisierten Normen, europäischen Normen oder den entsprechenden nationalen Normen entspricht.

This incomplete machine must not be put into service until the machinery into which it is to be incorporated has been declared in conformity with the provisions of the EC Machinery Directive, the harmonized standards, European standards, or the relevant national standards.

La mise en service de cette quasi-machine est interdite tant qu'il n'a pas été constaté que la machine dans laquelle elle doit être incorporée est conforme aux dispositions de la directive CE Machines, aux normes harmonisées, aux normes européennes ou aux normes nationales correspondantes.

Ort, Datum / place, date / lieu, date: Wertheim, 24.06.2025



(Dr. Constantin Schöler)

*Geschäftsführer / Managing Director / Gérant*

ppa.



(Jens Kaibel)

*Technischer Leiter / Technical Director /  
Directeur technique*

**VACUUBRAND GMBH + CO KG**

Alfred-Zippe-Str. 4  
97877 Wertheim

Tel.: +49 9342 808-0  
Fax: +49 9342 808-5555  
E-Mail: [info@vacuubrand.com](mailto:info@vacuubrand.com)  
Web: [www.vacuubrand.com](http://www.vacuubrand.com)

**VACUUBRAND®**

---

## DECLARATION OF CONFORMITY – China RoHS 2

---

VACUUBRAND GMBH + CO KG has made reasonable efforts to ensure that hazardous materials and substances may not be used in its products.

In order to determine the concentration of hazardous substances in all homogeneous materials of the subassemblies, a “Product Conformity Assessment” (PCA) procedure was performed. As defined in GB 26572-2025 the “Maximum Concentration Value” limits (MCV) apply to these restricted substances:

- Lead (Pb): 0.1%
- Mercury (Hg): 0.1%
- Cadmium (Cd): 0.01%
- Hexavalent chromium (Cr(+VI)): 0.1%
- Polybrominated biphenyls (PBB): 0.1%
- Polybrominated diphenyl ether (PBDE): 0.1%
- Dibutyl phthalate (DBP): 0.1%
- Benzyl butyl phthalate (BBP): 0.1%
- Bis(2-ethylhexyl) phthalate (DEHP): 0.1%
- Diisobutyl phthalate (DIBP): 0.1%

### Environmentally Friendly Use Period (EFUP)

EFUP defines the period in years during which the hazardous substances contained in electrical and electronic products will not leak or mutate under normal operating conditions. During normal use by the user such electrical and electronic products will not result in serious environmental pollution, cause serious bodily injury or damage to the user’s assets.

The Environmentally Friendly Use Period for VACUUBRAND products is 40 years.



VACUUBRAND®

部件名称 Part name	有害物质 / Hazardous substances									
	铅 (Pb)	汞 (Hg)	镉 (Cd)	六价铬 (Cr <sup>6+</sup> )	多溴联 苯 (PBB)	多溴二苯 醚 (PBDE)	邻苯二甲 酸二(2-乙 基己)酯 (DEHP)	邻苯二甲 酸丁 苯酯 (BBP)	邻苯二甲 酸二 丁酯 (DBP)	邻苯二甲 酸二 异丁酯 (DIBP)
包装 Packaging	○	○	○	○	○	○	○	○	○	○
塑料外壳 / 组件 Plastic housing / parts	○	○	○	○	○	○	○	○	○	○
真空油 Vacuum oil	○	○	○	○	○	○	○	○	○	○
电池 Battery	○	○	○	○	○	○	○	○	○	○
玻璃 Glass	X	○	○	○	○	○	○	○	○	○
电子电气组 件 Electrical and electronic parts	X	○	○	○	○	○	○	○	○	○
控制器 / 测 量设备 Controller / measuring device	X	○	○	○	○	○	○	○	○	○
金属外壳 / 组件 Metal housing / parts	X	○	○	○	○	○	○	○	○	○
电机 Motor	X	○	○	○	○	○	○	○	○	○
配件 Accessories	X	○	○	○	○	○	○	○	○	○

O: 表示该有害物质在该部件所有均质材料中的含量均在 GB 26572-2025 标准规定的限量要求以下。  
O: Indicates that the above mentioned hazardous substance contained in all homogeneous materials of the part is below the required limit as defined in GB 26572-2025.

X: 表示该有害物质在该部件至少一个均质材料中的含量超出 GB 26572-2025 标准规定的限量要求。  
X: Indicates that the above mentioned hazardous substance contained in at least one of the homogeneous materials of this part is above the required limit as defined in GB 26572-2025.

Declaration of Conformity – China RoHS 2

V5\_November 2025

**VACUUBRAND®**

电池、玻璃器皿和配件可能不属于所附设备所包含的内容，它们可能有各自单独的EFUP标记和/或可能正在维护其部件EFUP标记的更新。

Batteries, glassware and accessories might not be content of the enclosed device and may have its own EFUP-marking and/or might be maintaining parts with changing EFUP-marking.

除上表所示信息外，还需声明的是，这些部件并非是有意图用铅 (Pb), 汞 (Hg), 镉 (Cd), 六价铬 (Cr(+VI)), 多溴联苯 (PBB), 多溴二苯醚 (PBDE), 邻苯二甲酸二(2-乙基己)酯 (DEHP), 邻苯二甲酸丁苯酯 (BBP), 邻苯二甲酸二丁酯 (DBP), 邻苯二甲酸二异丁酯 (DIBP).

Apart from the disclosures in the above table, the subassemblies are not intentionally manufactured or formulated with lead (Pb), mercury (Hg), cadmium (Cd), hexavalent chromium (Cr+VI), polybrominated biphenyls (PBB), polybrominated diphenyl ethers (PBDE), dibutyl phthalate (DBP), benzyl butyl phthalate (BBP), bis(2-ethylhexyl) phthalate (DEHP), Diisobutyl phthalate (DIBP).

Products manufactured by VACUUBRAND may enter into further devices (e.g., rotary evaporator) or can be used together with other appliances (e.g., usage as booster pumps).

With these products and appliances in particular, please note the EFUP labeled on these products.

VACUUBRAND will not take responsibility for the EFUP of those products and appliances.

Place, date: Wertheim, 14.11.2025



(Dr. Constantin Schöler)  
Managing Director

ppa.



(Jens Kaibel)

Technical Director

**VACUUBRAND GMBH + CO KG**

Alfred-Zippe-Str. 4  
97877 Wertheim  
Germany

Tel.: +49 9342 808-0

Fax: +49 9342 808-5555

E-Mail: [info@vacuubrand.com](mailto:info@vacuubrand.com)

Web: [www.vacuubrand.com](http://www.vacuubrand.com)









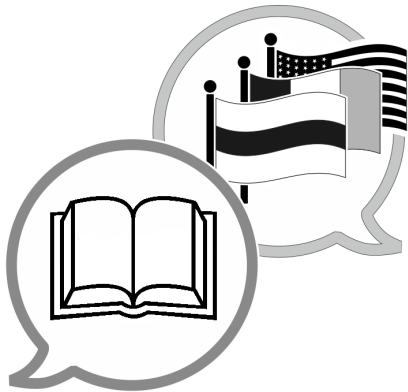

[www.vacuubrand.com/manuals](http://www.vacuubrand.com/manuals)

Manufacturer:

**VACUUBRAND GMBH + CO KG**  
**Alfred-Zippe-Str. 4**  
**97877 Wertheim**  
**GERMANY**

Phone:

Head office +49 9342 808-0  
Sales +49 9342 808-5550  
Service +49 9342 808-5660

Fax: +49 9342 808-5555

Email: [info@vacuubrand.com](mailto:info@vacuubrand.com)

Web: [www.vacuubrand.com](http://www.vacuubrand.com)