

# 化学真空系统 PC 520 select

网站链接



## 产品说明

对于一台泵同时运行两个独立的真空应用需求，此款化学真空系统是一个既经济又有效的解决方案。基础泵是备受欢迎的MZ 2C NT三级隔膜泵，PC 520 select常用于含常规溶剂的中等尺寸的真空应用。两个电子真空控制端口都内置单向止回阀，能够防止交叉污染互相影响。VACUU-SELECT真空控制器采用直观、基于应用程序的用户界面，覆盖了所有实验室常见真空应用。VACUU-SELECT真空控制器可满足您所有要求。对于简易实验过程可手动修改控制参数，直接蒸馏，或者通过简单的“拖放”操作编辑创建自己的应用程序。在溶剂蒸发过程中，电子控制端口能检测爆沸时压力，当溶剂沸点被探测到时切换至两点法控制，将压力维持在一个稳定的水平。进气口分离瓶由玻璃制成，外覆一层保护膜，能防止颗粒和液滴进入泵内，防止泵损坏，延长泵的使用寿命。当连接冷水管或循环制冷机时，出气口废气冷凝器可以实现溶剂将近100%回收，从而实现循环经济和环境保护。

## 性能特点

- 配置图形用户界面的VACUU-SELECT真空控制器能简化实验室工作
- 预定义的应用程序能节省时间，并得到可重复的结果
- 简易操作的应用编辑器允许编辑一系列自定义真空应用
- 性能强劲的真空泵具有优异的化学和冷凝液耐受性
- PC 520 select可以利用电子真空控制同时运行两个独立的真空应用

## 订购信息

产品名称	额定电源电压 工作频率	电源插头类型	订货号
PC 520 select	230 V   50-60 Hz	CEE	20733350

## 货品配置

真空系统安装完毕，连接即可使用，附带说明书

## 配件

- VACUU-SELECT用户管理 VACUU-SELECT User Management (20700900)
- DN 8-10mm (20636588)
- 橡胶真空管 DN 8 mm (20686001)
- 用于收集瓶的液面探测传感器 500 ml (20699908)
- 冷凝水阀 VKW-B (20674220)

技术指标

50 Hz 最大抽速 (mbar)	2 m <sup>3</sup> /h
60 Hz 最大抽速 (cfm)	1.4 cfm
极限真空	7 mbar / 5 torr
极限真空, 使用气镇	12 mbar / 9 torr
泵头数	2
泵级数	2
真空控制器	VACUU·SELECT
的允许环境温度范围 (运行)	10 - 40 °C
的允许环境温度范围 (存放)	-10 - 60 °C
最大出气口压力 (绝对压力)	1.1 bar
进气口连接	2 x 软管喷嘴接头 DN 8-10 mm
出气口连接	软管喷嘴接头 DN 8-10 mm
冷却液接口	2个 DN 6-8 mm 软管喷嘴接头
额定电机功率	0.18 kW
额定转速 50/60 Hz	1500/1800 min <sup>-1</sup>
防护等级	IP 20
尺寸 (长x宽x高)	435 mm x 272 mm x 457 mm
重量	18.4 kg
噪音水平 50 Hz/1500 Upm/62% (VARIO)/1500 Upm (VARIO-SP)/12500 Upm (VACUU·PURE®)	45 dBA
ATEX规格	II 3/- G Ex h IIC T3 Gc X Internal Atm. only
NRTL 标准	否
通讯	Ethernet (RJ45): Modbus TCP / USB (Type A): Data transfer, software update, RS-232 (additional adapter required)

50 Hz下的抽速曲线

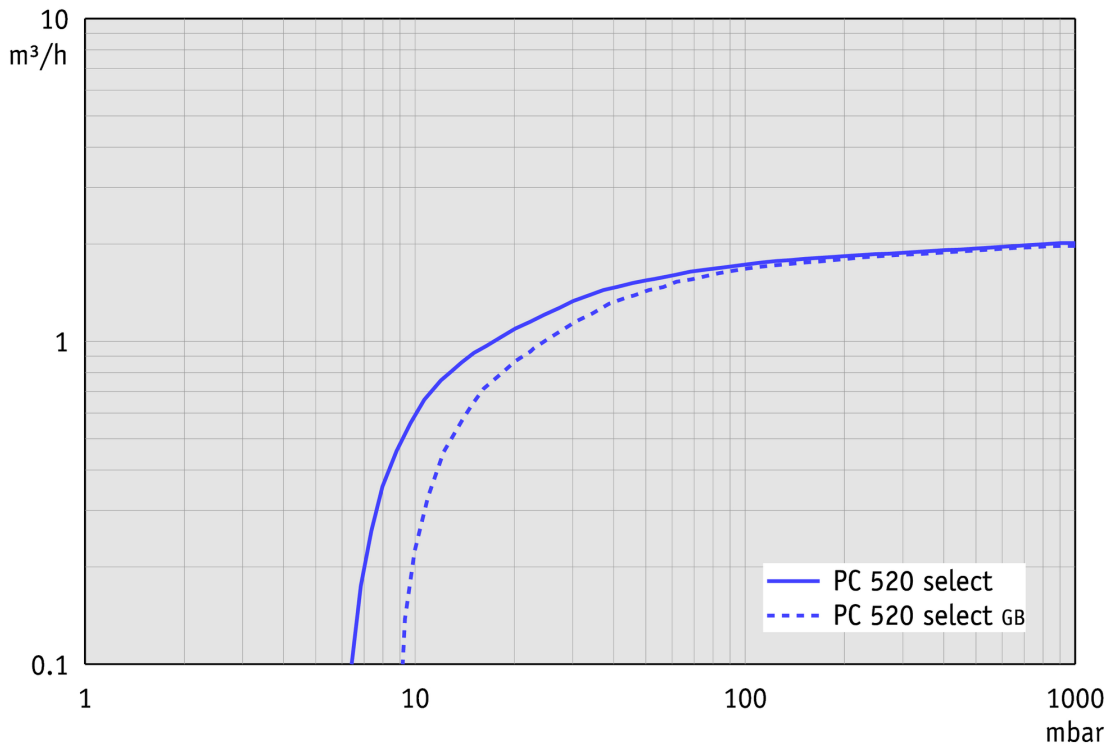

50 Hz下的抽气曲线 (10升容积)

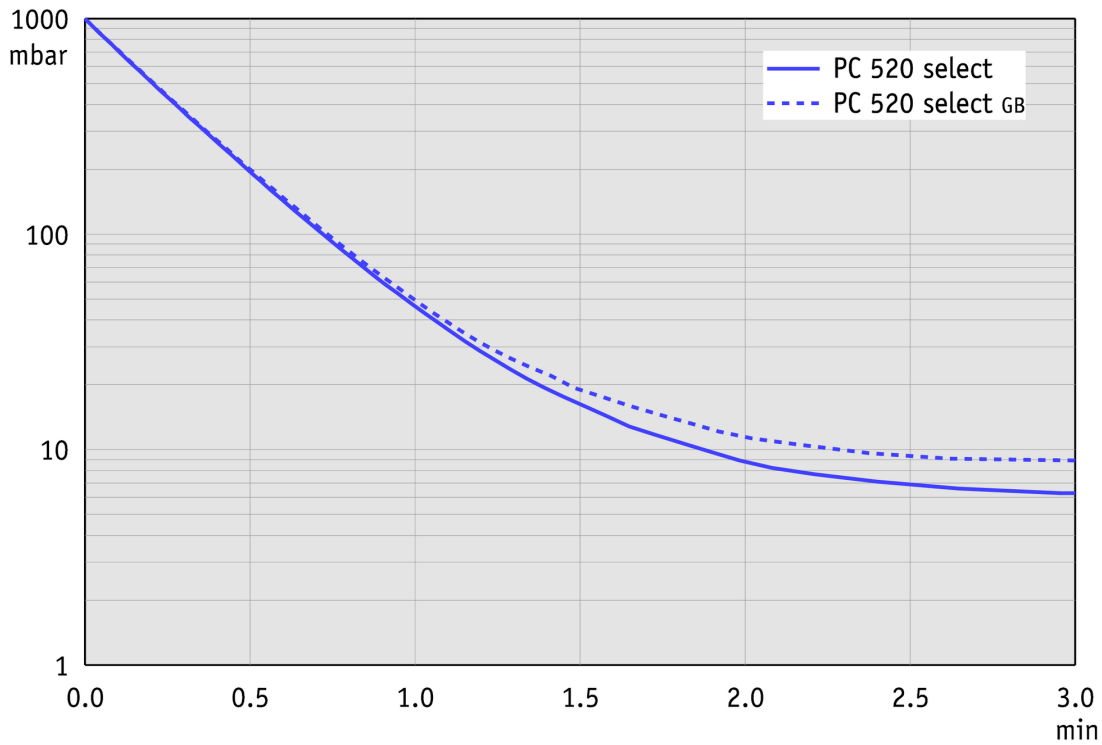

60 Hz下的抽速曲线

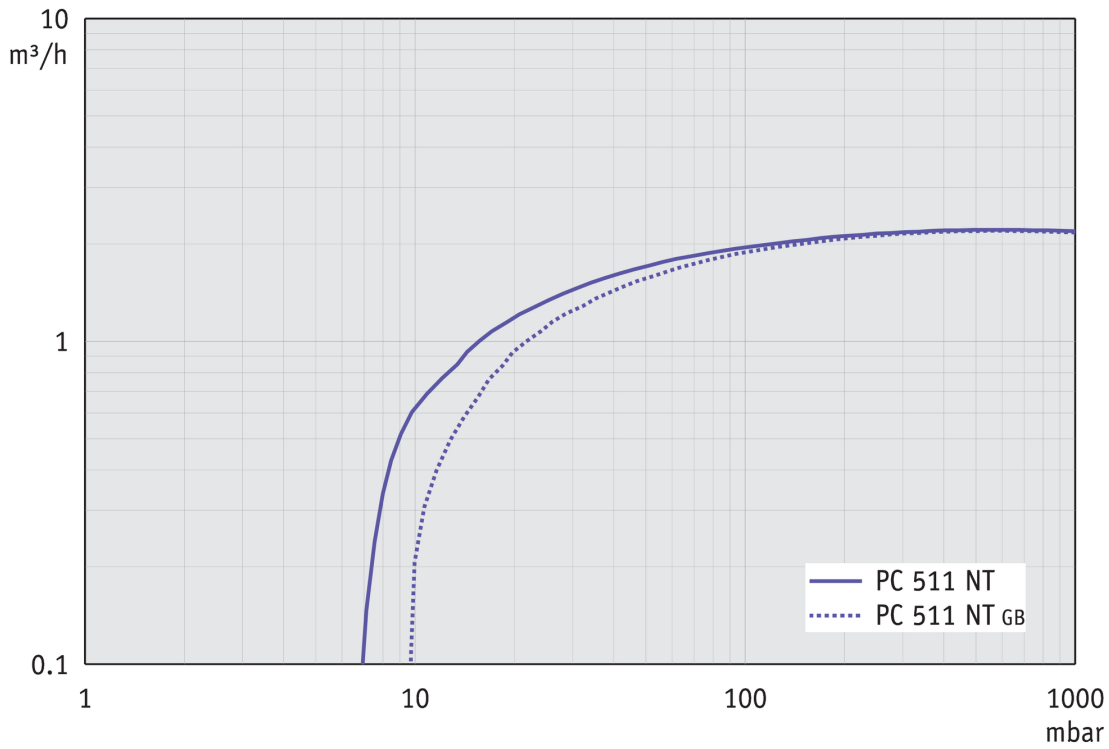

60 Hz下的抽气曲线 (10升容积)

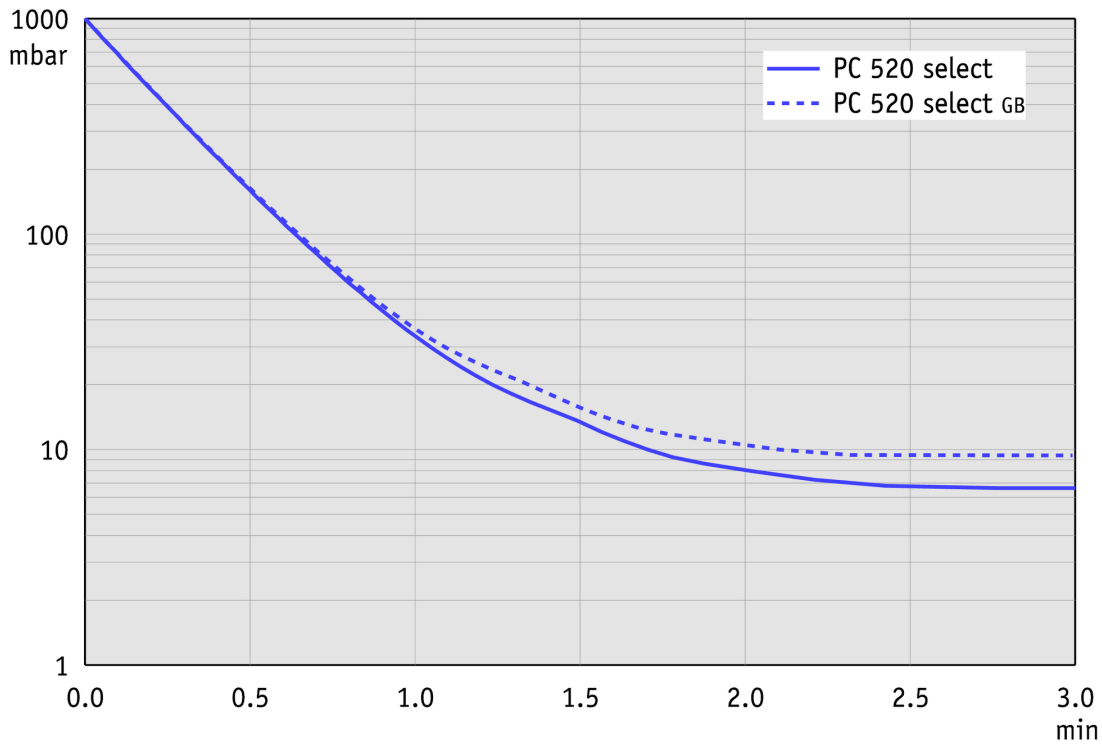

尺寸规格表

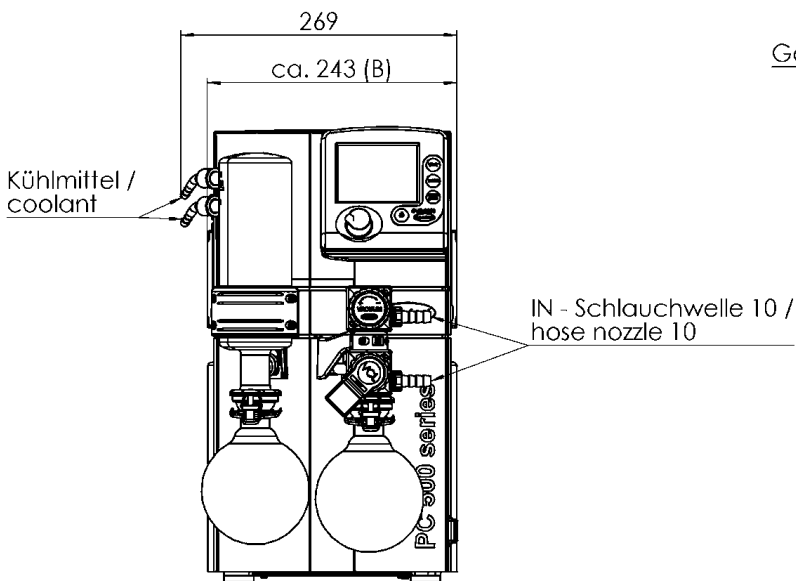

Alle Maße / all dimensions (mm)

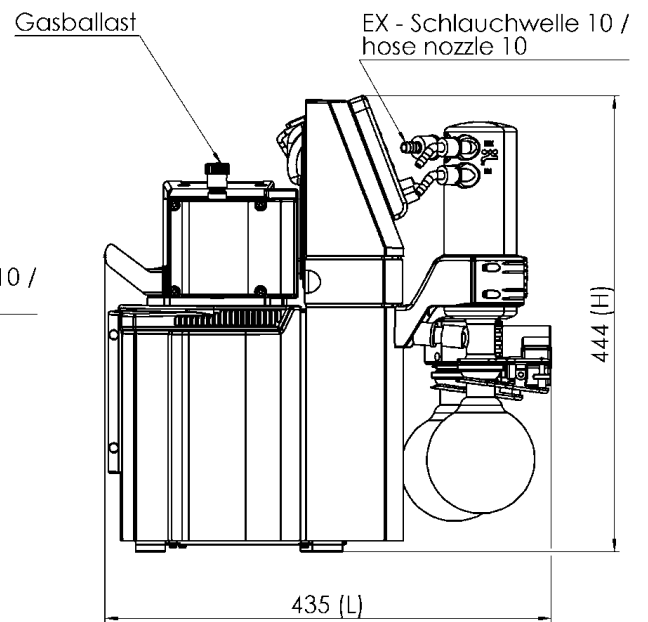

VACUUBRAND PC 511 NT KSG  
Version 2016/05/11

VACUUBRAND GMBH + CO KG  
P.O. Box 1664  
97877 Wertheim  
T +49 9342 808 5550  
F +49 9342 808 5555

info@vacuubrand.com  
www.vacuubrand.com

**VACUUBRAND®**

VACUUBRAND is part of the Brand group, a manufacturer of high-quality and innovative laboratory equipment and vacuum technology with a global team of approx. 1,000 employees.

With highly motivated and qualified employees, we manufacture the world's most comprehensive product family for vacuum generation, measurement and control for the rough and fine vacuum range in the laboratory.

**All with one goal:**

Enabling our customers to run reliable, safe and efficient processes. This is why we commit ourselves to continuous innovation, first-class performance, and outstanding quality.

Engineering excellence is central to our ability to deliver products and solutions renowned for their quality, durability, and reliability. Innovative technology, high quality materials and extensive testing deliver unmatched performance - engineered and manufactured in Germany.

Together with you, our experts will find the best solution for your application and provide you with first-class service along the way.

BRAND (Shanghai) Trading Co., Ltd.  
Shanghai, China

T +86 21 6422 2318  
info@brand.com.cn  
china.brand.com.cn

BRAND Scientific Equipment Pvt. Ltd.  
Mumbai, India

T +91 22 42957790  
customersupport@brand.co.in  
www.brand.co.in

BRANDTECH® Scientific, Inc.  
Essex, CT. United States of America

T +1 860 767 2562  
info@brandtech.com  
www.brandtech.com