

隔膜泵 ME 16 NT

[网站链接](#)

产品说明

隔膜泵是针对气体的一种持续的、无油抽气的优秀解决方案。单级泵的结构同时具有抽气速度大和达70mbar的极限真空的优点。所有与所抽介质接触的部件都是采用铝和经仔细挑选的塑料材质制成，广泛用于非腐蚀性气体的应用。高柔韧性的纤维增强的双层膜片采用氟橡胶（FPM）材质，延长了运行寿命。这些泵性能强劲，可提供非常大的抽速。八泵头的ME 16 NT 兼具抽速大，振动低及非常紧凑的结构设计，表面整洁，易于整理。

性能特点

- 无污染的抽气或排气过程
- 抽速大，即使接近极限真空时仍具有很高的抽气速度
- 排气安静
- 振动极低
- 超长的膜片寿命，无需维护的驱动系统，整体维护成本低

订购信息

产品名称	额定电源电压 工作频率	电源插头类型	订货号
ME 16 NT	120 V 50-60 Hz	US	20741003

货品配置

泵体安装完毕, 连接即可使用, 消音器, 附带说明书

配件

- 小法兰的中心支架 KF DN 20/25 (20660001)
- 小法兰外齐式环形中心支架 KF DN 20/25 (20660196)
- PVC真空管, 内置不锈钢螺线, 带小法兰 KF DN 25 (20686021)
- 带软管喷嘴接头的小法兰 KF DN 25 / DN 10 mm (20662807)
- 橡胶真空管 DN 10 mm (20686002)

技术指标

50 Hz 最大抽速 (mbar)	16.4 m ³ /h
60 Hz 最大抽速 (cfm)	9.6 cfm
极限真空	70 mbar / 53 torr
泵头数	8
泵级数	1
的允许环境温度范围 (运行)	10 - 40 °C
的允许环境温度范围 (存放)	-10 - 60 °C
最大出气口压力 (绝对压力)	1.1 bar
进气口连接	KF DN 25 小法兰
出气口连接	G1/2"
额定电机功率	0.53 kW
额定转速 50/60 Hz	1650 min ⁻¹
防护等级	IP 40
尺寸 (长×宽×高)	554 mm x 260 mm x 359 mm
重量	30.3 kg
噪音水平 50 Hz/1500 Upm/62% (VARIO)/1500 Upm (VARIO-SP)/12500 Upm (VACUU·PURE®)	54 dBA
NRTL 标准	否

50 Hz下的抽速曲线

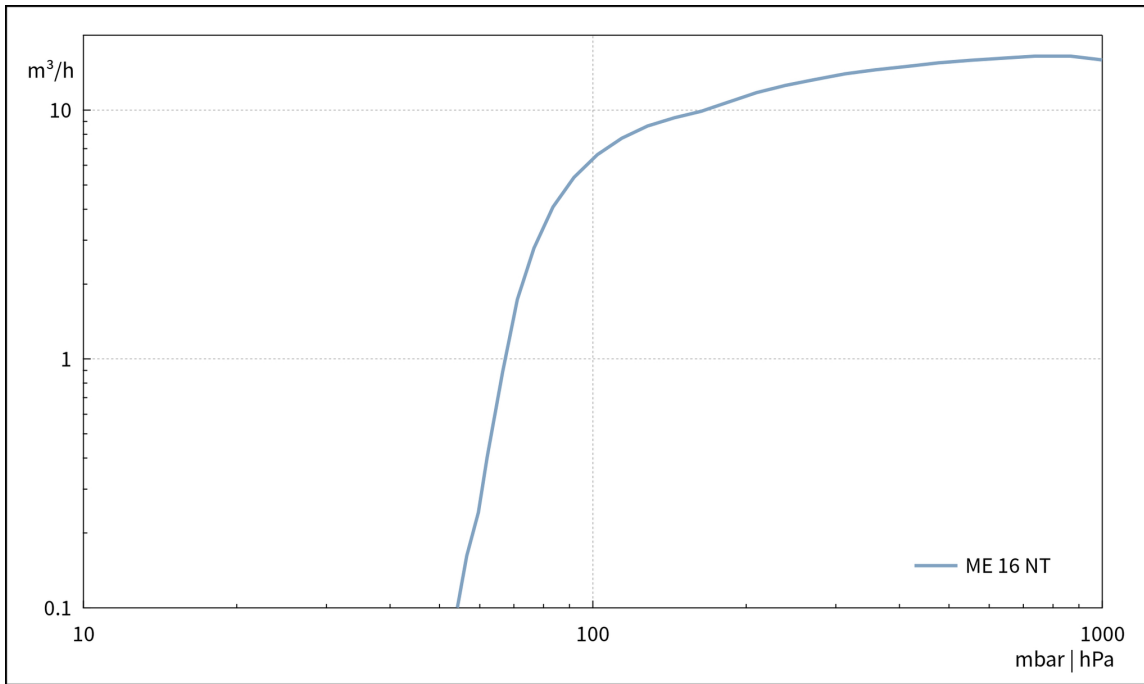

50 Hz下的抽气曲线 (100升容积)

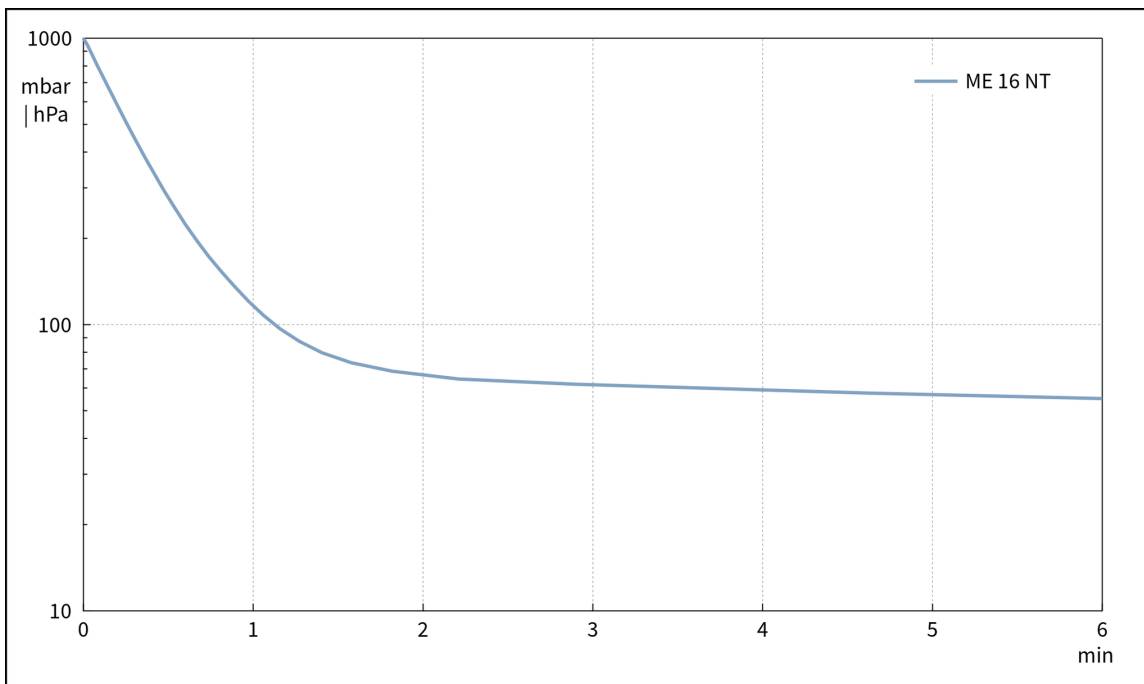

尺寸规格表

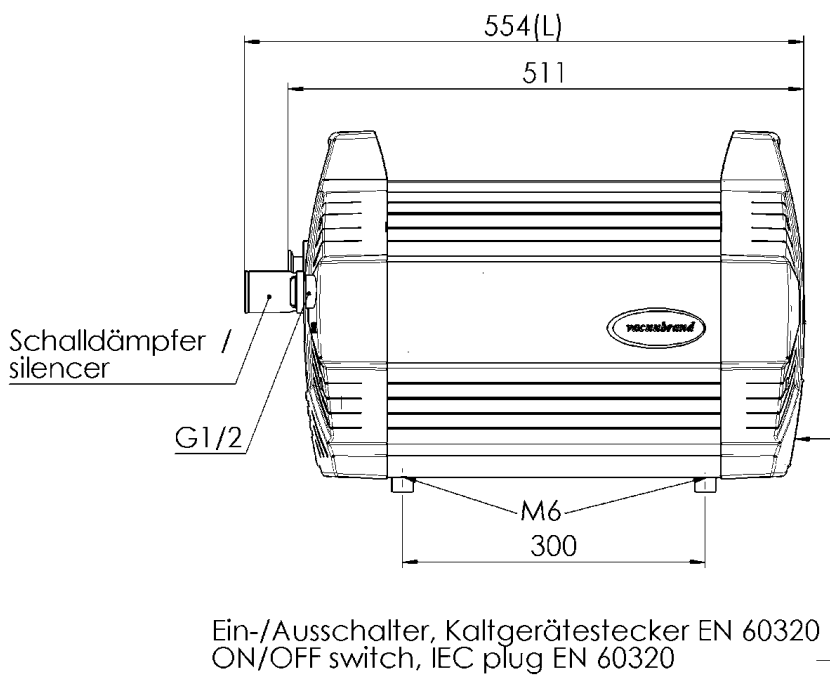

Alle Maße / all dimensions (mm)

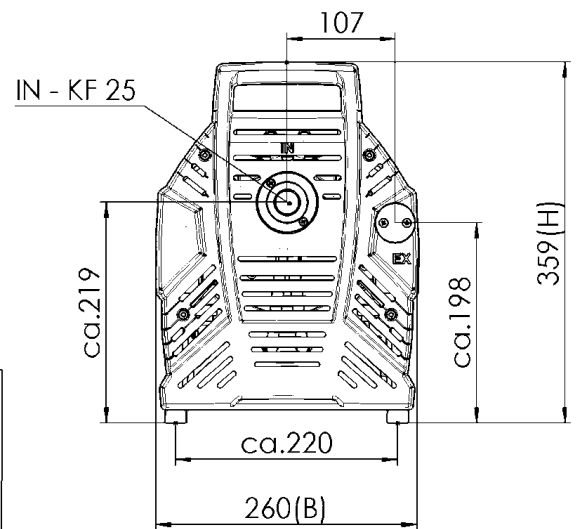

VACUUBRAND ME16 MD12 MV10 NT
Version 2014/06/18

VACUUBRAND GMBH + CO KG
P.O. Box 1664
97877 Wertheim
T +49 9342 808 5550
F +49 9342 808 5555

info@vacuubrand.com
www.vacuubrand.com

VACUUBRAND®

VACUUBRAND is part of the Brand group, a manufacturer of high-quality and innovative laboratory equipment and vacuum technology with a global team of approx. 1,000 employees.

With highly motivated and qualified employees, we manufacture the world's most comprehensive product family for vacuum generation, measurement and control for the rough and fine vacuum range in the laboratory.

All with one goal:

Enabling our customers to run reliable, safe and efficient processes. This is why we commit ourselves to continuous innovation, first-class performance, and outstanding quality.

Engineering excellence is central to our ability to deliver products and solutions renowned for their quality, durability, and reliability. Innovative technology, high quality materials and extensive testing deliver unmatched performance - engineered and manufactured in Germany.

Together with you, our experts will find the best solution for your application and provide you with first-class service along the way.

BRAND (Shanghai) Trading Co., Ltd.
Shanghai, China

T +86 21 6422 2318
info@brand.com.cn
china.brand.com.cn

BRAND Scientific Equipment Pvt. Ltd.
Mumbai, India

T +91 22 42957790
customersupport@brand.co.in
www.brand.co.in

BRANDTECH® Scientific, Inc.
Essex, CT. United States of America

T +1 860 767 2562
info@brandtech.com
www.brandtech.com