

# 化学隔膜泵

## MD 12C NT VARIO select

[网站链接](#)

### 产品说明

对于需要高抽速和使用高沸点溶剂的用户，MD 12C NT VARIO select是一个很好的解决方案。由于其耐化学腐蚀氟聚合物和全氟弹性体润湿材料的可靠性，该泵为搭配落地式旋转蒸发器、真空干燥炉、真空蒸馏塔和其它类似应用提供可靠的性能。集成式的VACUU-SELECT真空控制器搭配了简单易用、基于应用程序的用户界面，内嵌了所有常见的实验室真空应用。VACUU-SELECT真空控制器可满足您所有要求。对于简易实验过程可手动修改控制参数，也可进行全自动蒸馏，或者通过简单的“拖放”操作编辑创建自己的应用程序。在溶剂蒸发过程中，VACUU-SELECT真空控制器能够持续探测溶剂沸点，并自动调节真空过程，维持过程控制。通过变频控制，泵只按需要的速度运行。这延长了维修间隔并且泵运行安静。

### 性能特点

- 配置图形用户界面及预定义应用的VACUU-SELECT真空控制器能简化实验室工作
- 自动沸点探测及真空度调节能够缩短反应时间
- 满足高真空需求，如大量的绝大多数高沸点溶剂
- 超长的膜片寿命，维护周期长且维护成本低

## 订购信息

产品名称	额定电源电压 工作频率	电源插头类型	订货号
MD 12C NT VARIO select	200-230 V   50-60 Hz	CEE	25743750
MD 12C NT VARIO select	200-230 V   50-60 Hz	UK	25743752
MD 12C NT VARIO select	100-120 V   50-60 Hz	US	25743753
MD 12C NT VARIO select	200-230 V   50-60 Hz	CN	25743756
MD 12C NT VARIO select	200-230 V   50-60 Hz	IN	25743757

## 货品配置

泵体安装完毕，连接即可使用，附带说明书

## 配件

- VACUU·SELECT用户管理 VACUU·SELECT User Management (20700900)
- DN 8-10mm (20636588)
- 小法兰的中心支架 KF DN 20/25 (20660001)
- 小法兰外齐式环形中心支架 KF DN 20/25 (20660196)
- PVC真空管，内置不锈钢螺线，带小法兰 KF DN 25 (20686021)
- 带软管喷嘴接头的小法兰 KF DN 25 / DN 10 mm (20662807)
- 橡胶真空管 DN 10 mm (20686002)

## 技术指标

50 Hz 最大抽速 (mbar)	14.3 m <sup>3</sup> /h
60 Hz 最大抽速 (cfm)	8.4 cfm
极限真空	1.5 mbar / 1.1 torr
极限真空, 使用气镇	3 mbar / 2.2 torr
泵头数	8
泵级数	3
真空控制器	VACUU-SELECT
的允许环境温度范围 (运行)	10 - 40 °C
的允许环境温度范围 (存放)	-10 - 60 °C
最大出气口压力 (绝对压力)	1.1 bar
进气口连接	KF DN 25 小法兰
出气口连接	DN 15 mm 软管喷嘴接头
额定电机功率	0.53 kW
电机转速范围	30 - 2400 min <sup>-1</sup>
防护等级	IP 40
尺寸 (长x宽x高)	533 mm x 260 mm x 450 mm
重量	28.9 kg
噪音水平 50 Hz/1500 Upm/62% (VARIO)/1500 Upm (VARIO-SP)/12500 Upm (VACUU-PURE®)	47 dBA
NRTL 标准	否
通讯	Ethernet (RJ45): Modbus TCP / USB (Type A): Data transfer, software update, RS-232 (additional adapter required)

50 Hz下的抽速曲线

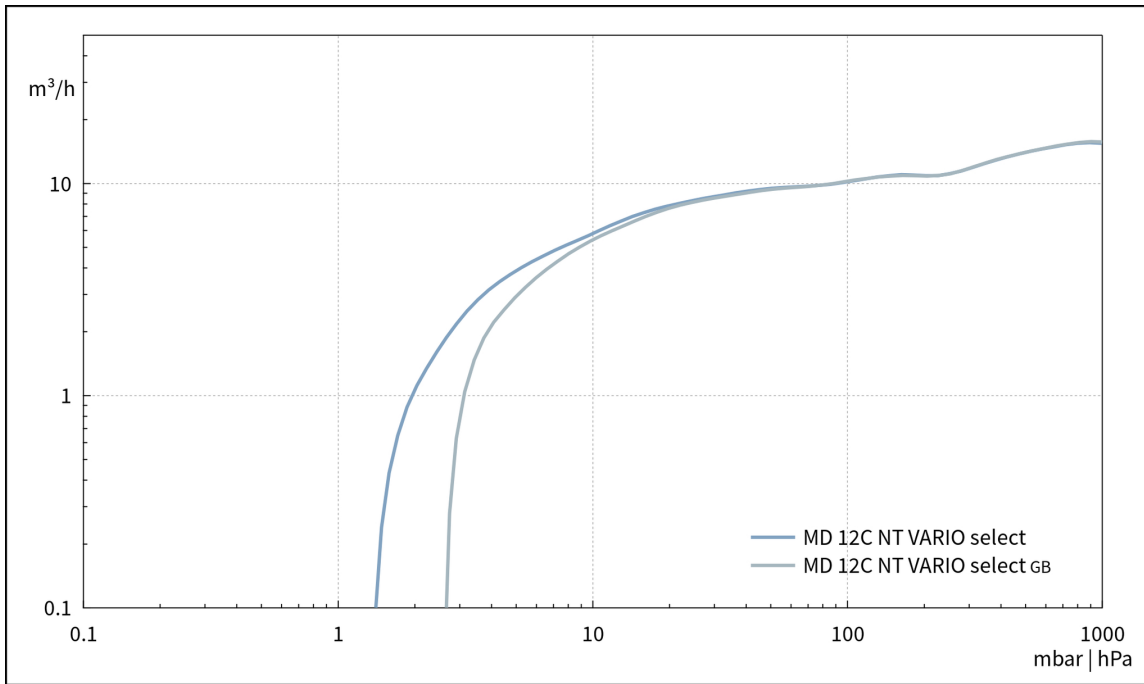

50 Hz下的抽气曲线 (100升容积)

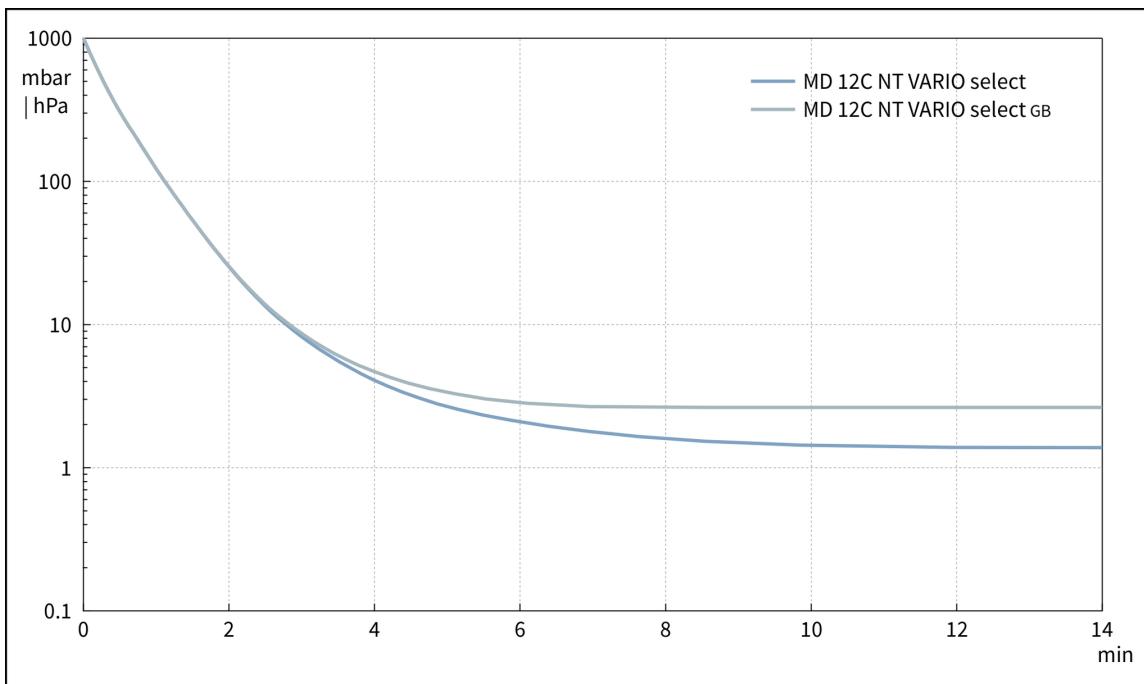

60 Hz下的抽速曲线

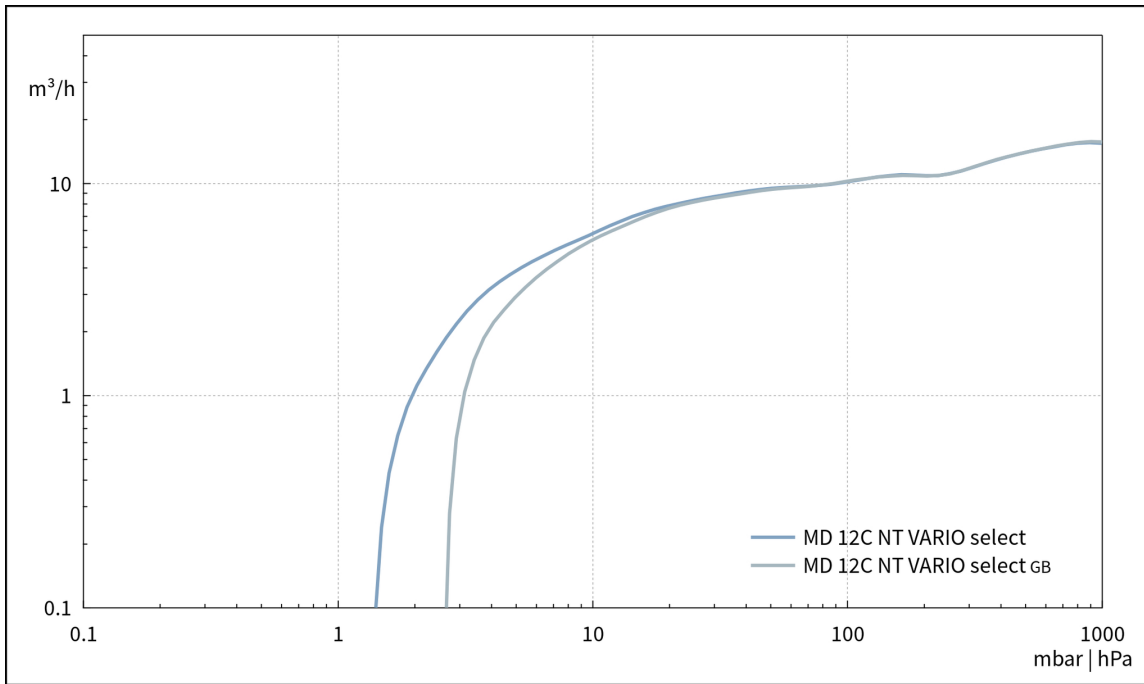

60 Hz下的抽气曲线 (100升容积)

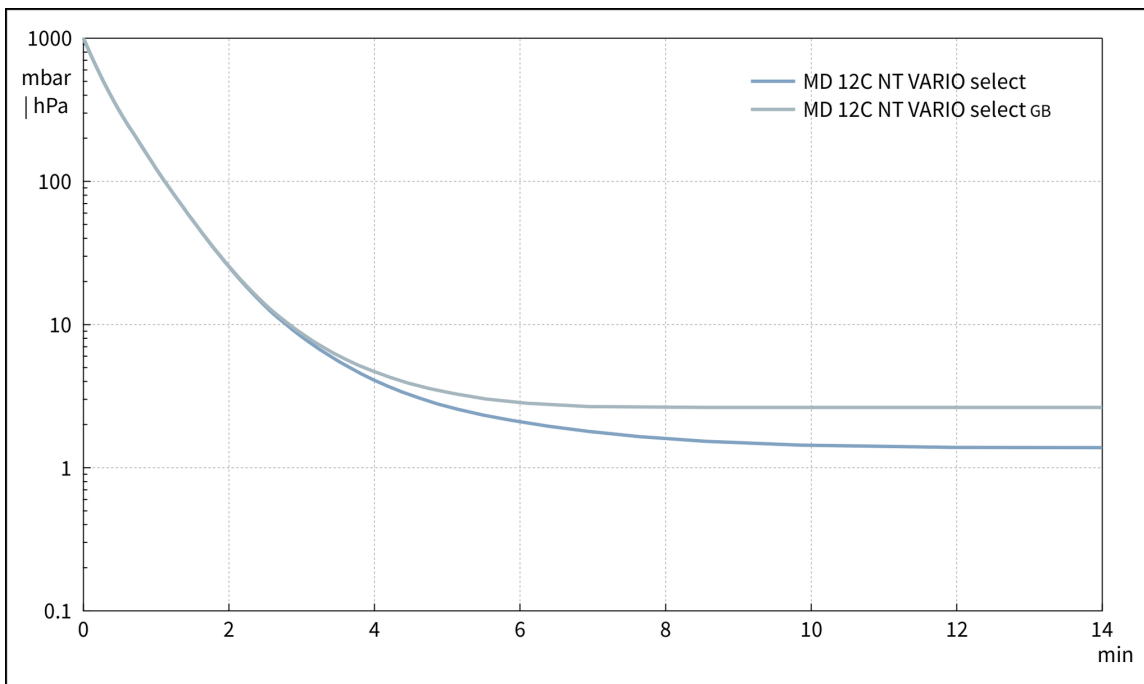

尺寸规格表

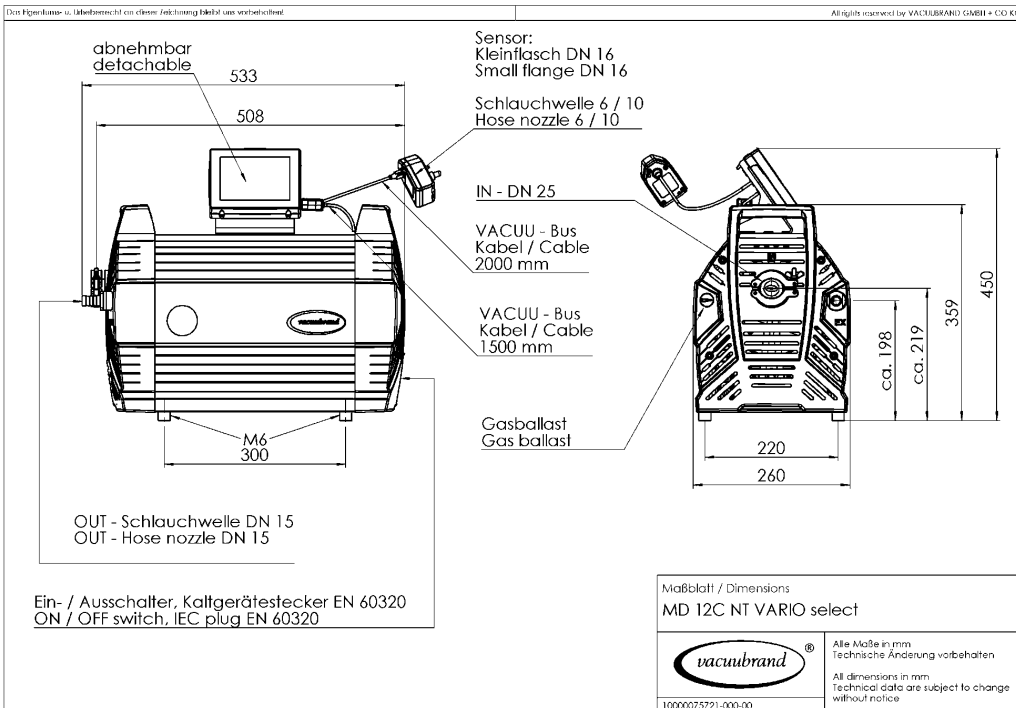

VACUUBRAND GMBH + CO KG  
P.O. Box 1664  
97877 Wertheim  
T +49 9342 808 5550  
F +49 9342 808 5555

info@vacuubrand.com  
www.vacuubrand.com

**VACUUBRAND®**

VACUUBRAND is part of the Brand group, a manufacturer of high-quality and innovative laboratory equipment and vacuum technology with a global team of approx. 1,000 employees.

With highly motivated and qualified employees, we manufacture the world's most comprehensive product family for vacuum generation, measurement and control for the rough and fine vacuum range in the laboratory.

**All with one goal:**

Enabling our customers to run reliable, safe and efficient processes. This is why we commit ourselves to continuous innovation, first-class performance, and outstanding quality.

Engineering excellence is central to our ability to deliver products and solutions renowned for their quality, durability, and reliability. Innovative technology, high quality materials and extensive testing deliver unmatched performance - engineered and manufactured in Germany.

Together with you, our experts will find the best solution for your application and provide you with first-class service along the way.

BRAND (Shanghai) Trading Co., Ltd.  
Shanghai, China

T +86 21 6422 2318  
info@brand.com.cn  
china.brand.com.cn

BRAND Scientific Equipment Pvt. Ltd.  
Mumbai, India

T +91 22 42957790  
customersupport@brand.co.in  
www.brand.co.in

BRANDTECH® Scientific, Inc.  
Essex, CT. United States of America

T +1 860 767 2562  
info@brandtech.com  
www.brandtech.com