

Diaphragm pump ME 16 NT

[Link to the website](#)



Product description

Diaphragm pumps are an excellent solution for continuous, oil-free evacuation and pumping of gases. The one-stage design provides the advantageous combination of high pumping speed and low ultimate vacuum down to 70 mbar. All parts in contact with pumped media are made of aluminum and selected plastics allowing a wide range of applications for non-corrosive gases. The highly flexible, fabric-reinforced double diaphragms made of FKM are ideal for extended operating life. These pumps are particularly powerful and offer large volume flow. The eight-cylinder pump ME 16 NT features exceptionally high pumping speed, low vibration and a very compact design with smooth and easy-to-clean surfaces.

Performance features

- contamination-free pumping and evacuation
- high flow rate even near ultimate vacuum
- whisper quiet
- very low vibration
- exceptionally long diaphragm life and maintenance-free drive system for low lifetime costs

Ordering data

Product name	Nominal mains voltage mains frequency	Plug type	Articleno.
ME 16 NT	200-230 V 50-60 Hz	CEE	20741000

Items supplied

Pump completely mounted, ready for use, silencer, with manual.

Accessories

- Clamping ring for small flange KF DN 20/25 (20660001)
- External centring ring for small flange KF DN 20/25 (20660196)
- Vacuum tubing PVC with internal stainless steel spiral, with small flanges KF DN 25 (20686021)
- Small flange with hose nozzle KF DN 25 / DN 10 mm (20662807)
- Rubber vacuum tubing DN 10 mm (20686002)

Technical data

Max. pumping speed 50 Hz (mbar)	16.4 m ³ /h
Max. pumping speed 60 Hz (cfm)	9.6 cfm
Ultimate vacuum	70 mbar / 53 torr
Number of heads	8
Number of stages	1
Permissible ambient temperature range (operation)	10 - 40 °C
Permissible ambient temperature range (storage)	-10 - 60 °C
Max. outlet pressure (abs.)	1.1 bar
Inlet connection	small flange KF DN 25
Outlet connection	G1/2"
Rated motor power	0.53 kW
Rated speed 50/60 Hz	1650 min ⁻¹
Protection class IEC 60529	IP 40
Dimensions (L x W x H)	554 mm x 260 mm x 359 mm
Weight	30.2 kg
Noise (sound pressure level) in dBA at 50 Hz or 1500 rpm/62% (VARIO)/1500 rpm (VARIO-SP)/12500 Upm (VACUU·PURE®)	54 dBA
ATEX conformity	II 3/- G Ex h IIC T3 Gc X Internal Atm. only
NRTL certification	No

Pumping speed graph at 50 Hz

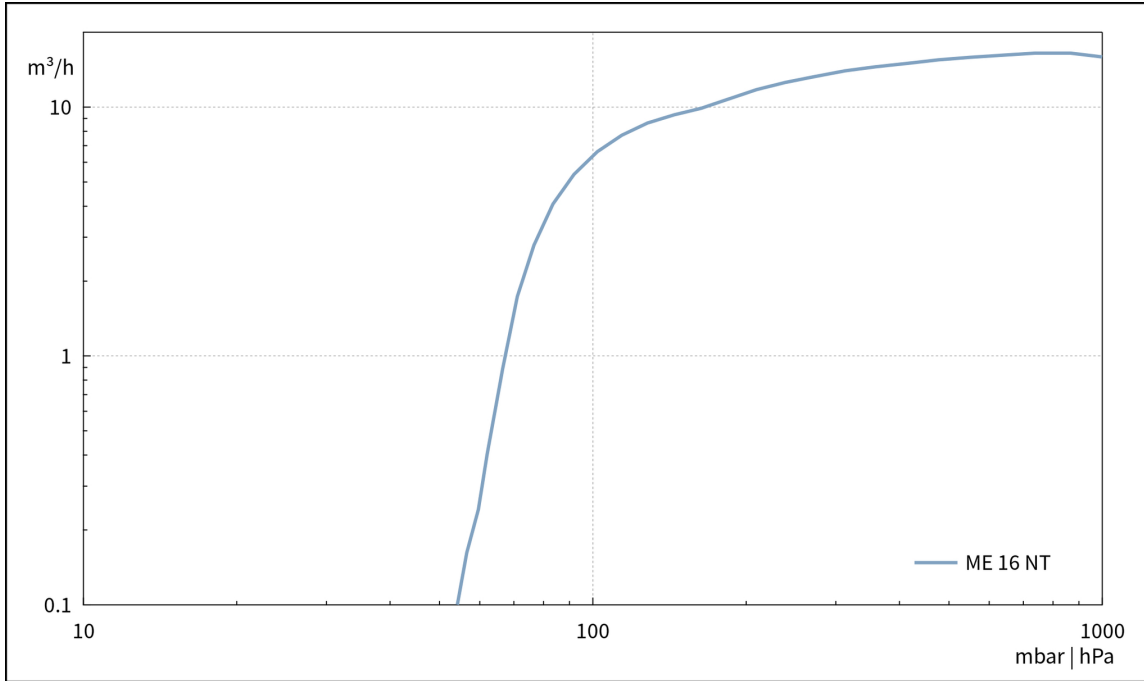

Pump down graph at 50 Hz (100 l volume)

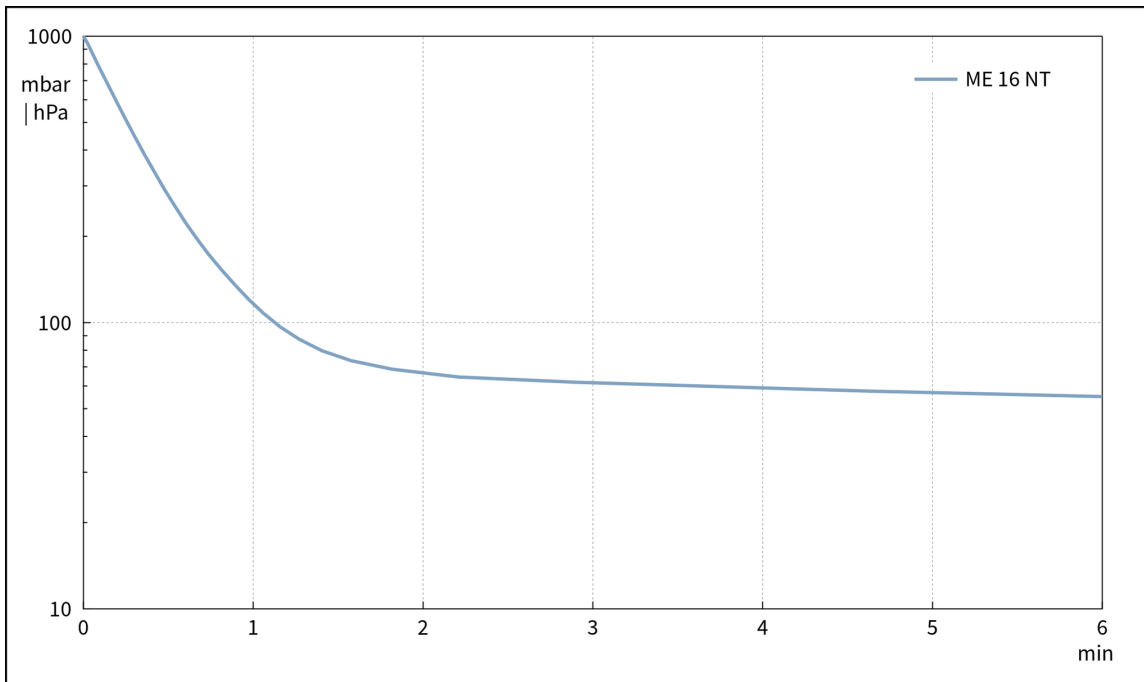

Dimension sheet

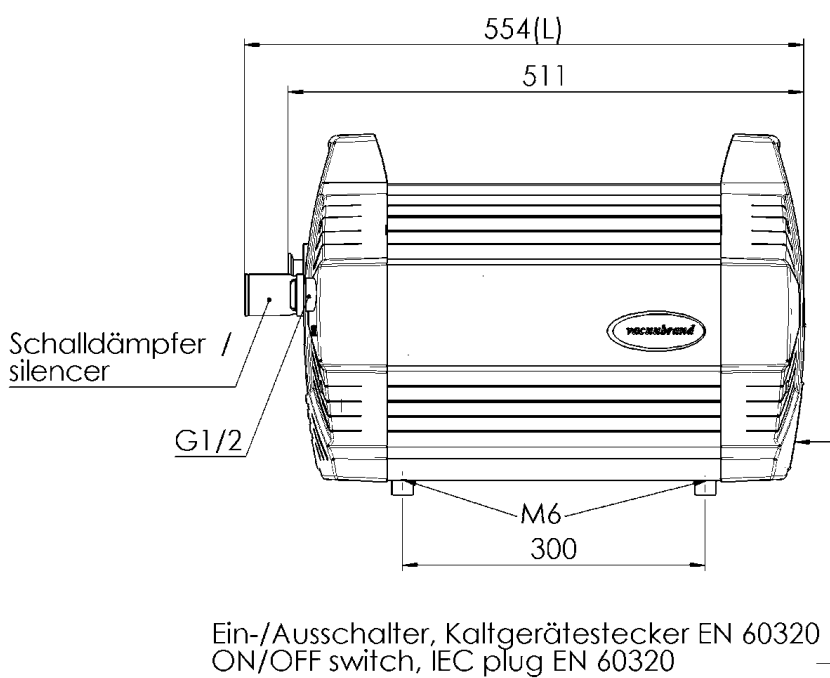

Alle Maße / all dimensions (mm)

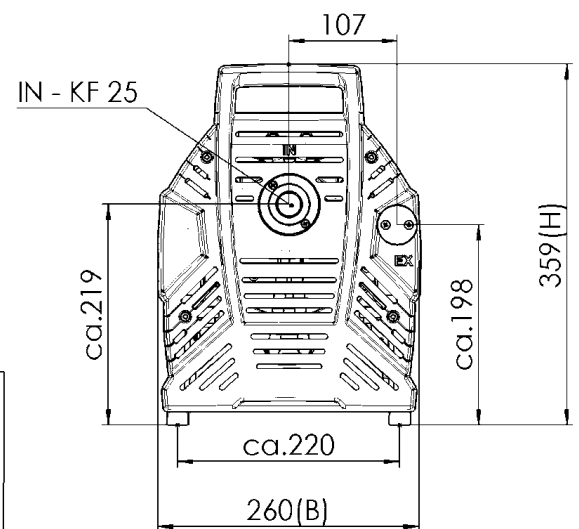

VACUUBRAND ME16 MD12 MV10 NT
Version 2014/06/18

VACUUBRAND GMBH + CO KG
P.O. Box 1664
97877 Wertheim
T +49 9342 808 5550
F +49 9342 808 5555

info@vacuubrand.com
www.vacuubrand.com

VACUUBRAND®

VACUUBRAND is part of the Brand group, a manufacturer of high-quality and innovative laboratory equipment and vacuum technology with a global team of approx. 1,000 employees.

With highly motivated and qualified employees, we manufacture the world's most comprehensive product family for vacuum generation, measurement and control for the rough and fine vacuum range in the laboratory.

All with one goal:

Enabling our customers to run reliable, safe and efficient processes. This is why we commit ourselves to continuous innovation, first-class performance, and outstanding quality.

Engineering excellence is central to our ability to deliver products and solutions renowned for their quality, durability, and reliability. Innovative technology, high quality materials and extensive testing deliver unmatched performance - engineered and manufactured in Germany.

Together with you, our experts will find the best solution for your application and provide you with first-class service along the way.

BRAND (Shanghai) Trading Co., Ltd.
Shanghai, China

T +86 21 6422 2318
info@brand.com.cn
china.brand.com.cn

BRAND Scientific Equipment Pvt. Ltd.
Mumbai, India

T +91 22 42957790
customersupport@brand.co.in
www.brand.co.in

BRANDTECH® Scientific, Inc.
Essex, CT. United States of America

T +1 860 767 2562
info@brandtech.com
www.brandtech.com