

Fluid aspiration system BVC basic G



[Link to the website](#)

Product description

The BioChem-VacuuCenter BVC basic is designed for connection to an existing external vacuum source like a diaphragm pump or a vacuum network (e.g., VACUU-LAN®) and does not require electric power. The chemical-resistant mechanical vacuum controller always ensures an optimal operating vacuum. The controller opens only when needed thus limiting the gas load on the vacuum source. The evaporation of collected liquid is minimized. The inlet tubing integrated in the bottle head reduces aerosol and foam formation and ensures a long service life of the hydrophobic protection filter. The aspiration system is available either as BVC basic with 4l PP bottle or as BVC basic G with 2l coated borosilicate glass bottle.

Performance features

- mechanical vacuum regulator and integrated check valve to provide optimum working vacuum and minimize the vapor load on the vacuum network
- stable base and electricity-free operation for convenience
- autoclavable collection bottle designed to reduce aerosol and foam formation; autoclavable quick-couplings available as accessory
- aspiration hand set VacuuHandControl (VHC^{PTO}) with flow-through suction tube - no contamination of handle by aspirated media
- hydrophobic 0.2 µm sterilizable filter - contamination risks for the vacuum pumping system are greatly reduced; autoclavable as complete unit together with the collection bottle

Ordering data

Product name	Nominal mains voltage mains frequency	Plug type	Articleno.
BVC basic G			20727100

Items supplied

Complete fluid aspiration system for existing vacuum source, with automatic vacuum controll, hose nozzle DN 6/10 mm for connection to a vacuum supply, aspiration hand set VacuuHandControl VHC, collection bottle 2l made of glass, protection filter and manual.

Accessories

- VacuuHandControl VHC^{PRO} (20688061)
- BVC 2l bottle glass BVC (20635809)
- Bottle 2L glass, with cap unmachined (w/o filter, connection for hose, blind plug) BVC (20635871)
- Table stand for VHC^{PRO} VHC^{PRO} (20635680)
- 8-channel tip adapter with ejector, for VacuuHandControl VHCpro BVC (20635679)

Technical data

Vacuum controller	Mechanical vacuum controller
Collection bottle	2l Glass
Permissible ambient temperature range (operation)	10 - 40 °C
Permissible ambient temperature range (storage)	-10 - 60 °C
Max. outlet pressure (abs.)	1.1 bar
Inlet connection	Suction controller
Outlet connection	Hose nozzle DN 6-10 mm
Protection class IEC 60529	IP 54
Dimensions (L x W x H)	230 mm x 180 mm x 430 mm
Weight	3.2 kg
NRTL certification	No

Dimension sheet

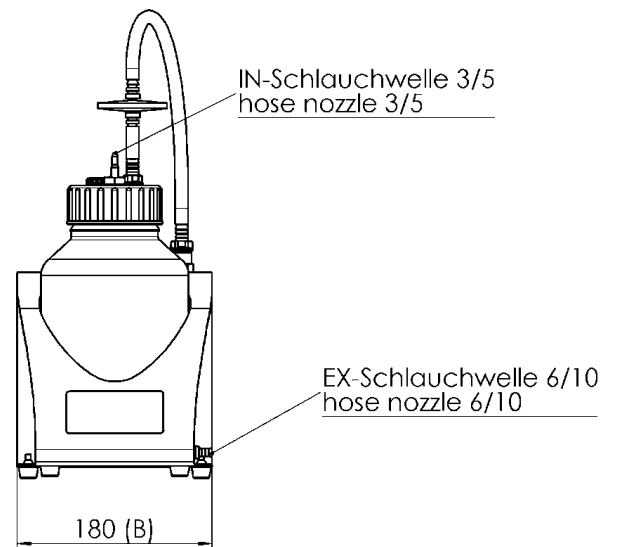
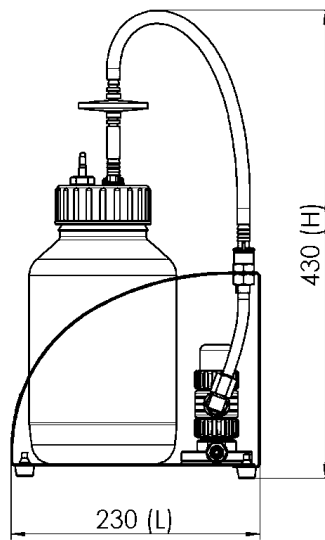
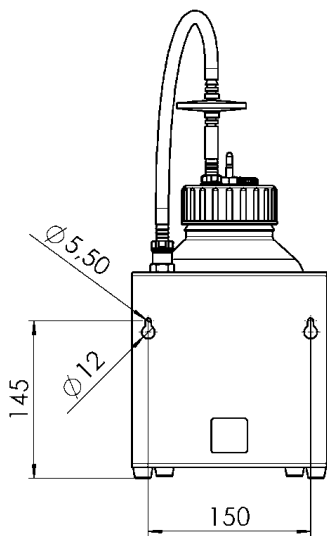

Alle Maße / all dimensions (mm)

VACUUBRAND BVC basic G
Version 2012/10/09

VACUUBRAND GMBH + CO KG
P.O. Box 1664
97877 Wertheim
T +49 9342 808 5550
F +49 9342 808 5555

info@vacuubrand.com
www.vacuubrand.com

VACUUBRAND®

VACUUBRAND is part of the Brand group, a manufacturer of high-quality and innovative laboratory equipment and vacuum technology with a global team of approx. 1,000 employees.

With highly motivated and qualified employees, we manufacture the world's most comprehensive product family for vacuum generation, measurement and control for the rough and fine vacuum range in the laboratory.

All with one goal:

Enabling our customers to run reliable, safe and efficient processes. This is why we commit ourselves to continuous innovation, first-class performance, and outstanding quality.

Engineering excellence is central to our ability to deliver products and solutions renowned for their quality, durability, and reliability. Innovative technology, high quality materials and extensive testing deliver unmatched performance - engineered and manufactured in Germany.

Together with you, our experts will find the best solution for your application and provide you with first-class service along the way.

BRAND (Shanghai) Trading Co., Ltd.
Shanghai, China

T +86 21 6422 2318
info@brand.com.cn
china.brand.com.cn

BRAND Scientific Equipment Pvt. Ltd.
Mumbai, India

T +91 22 42957790
customersupport@brand.co.in
www.brand.co.in

BRANDTECH® Scientific, Inc.
Essex, CT. United States of America

T +1 860 767 2562
info@brandtech.com
www.brandtech.com