

# Chemistry diaphragm pump MV 10C EX +AK+EK

[Link to the website](#)



## Product description

ATEX chemistry vacuum systems are ready for use for applications with large amounts of condensable vapors due to optimally configured accessories. Typical applications are rotary evaporators and drying ovens with potentially explosive atmospheres. The separator at the inlet (AK) retains particles and liquid droplets. The waste vapor condenser at the outlet (EK) is highly efficient and compact. The condenser enables near-100-percent solvent recovery. Included in delivery is a separate gas ballast connection part for use with inert gas.

## Performance features

- outstanding chemical resistance and superior vapor tolerance
- flame proof motor with integrated, self-locking overload and excess temperature protection for direct 230V / 50Hz single phase power supply. No need for any additional and specific overcurrent protection device
- overpressure safety relief valves internally and at outlet
- safety diaphragm technology with option for inert gas purge and detection of diaphragm breakage
- separator AK and emission condenser EK for pump protection and solvent recovery

## Ordering data

Product name	Nominal mains voltage   mains frequency	Plug type	Articleno.
MV 10C EX +AK+EK	230 V   50 Hz	Open wires	22614250

## Items supplied

Pumping unit completely mounted with inlet separator and emission condenser, ready for use, with manual, 2 m cable without plug at each of the two motors. Shatter and shock protection for glass parts are to be provided by the customer.

## Accessories

## Technical data

Max. pumping speed 50 Hz (mbar)	8.1 m <sup>3</sup> /h
Ultimate vacuum	2 mbar / 1.5 torr
Ultimate vacuum with gas ballast	10 mbar / 7.5 torr
Number of heads	8
Number of stages	4
Permissible ambient temperature range (operation)	10 - 40 °C
Permissible ambient temperature range (storage)	-10 - 60 °C
Max. outlet pressure (abs.)	1.1 bar
Inlet connection	small flange KF DN 25
Outlet connection	Hose nozzle DN 8-10 mm
Coolant connection	2 x hose nozzle DN 6-8 mm
Rated motor power	0.5 kW
Rated speed 50/60 Hz	1500 min <sup>-1</sup>
Protection class IEC 60529	IP 54
Dimensions (L x W x H)	649 mm x 525 mm x 452 mm
Weight	64 kg
Noise (sound pressure level) in dBA at 50 Hz or 1500 rpm/62% (VARIO)/1500 rpm (VARIO-SP)/12500 Upm (VACUU·PURE®)	52 dBA
ATEX conformity	Pumping chamber (pumped gases): II 2G Ex h IIC T3 Gb X Environment with inert purge gas: II 2G Ex h IIB T4 Gb X Environment without inert purge gas: II 3G Ex h IIB T4 Gc X Motor: II 2G Ex db IIB T4 Gb
NRTL certification	No

Pumping speed graph at 50 Hz

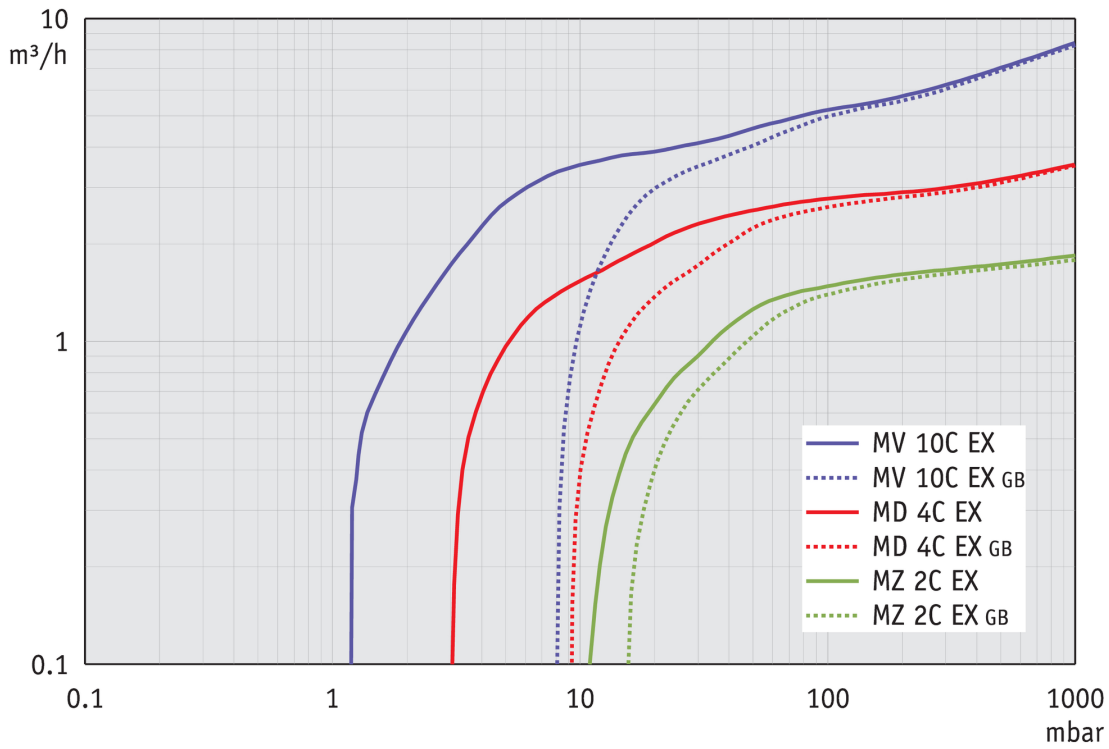

Pump down graph at 50 Hz (100 l volume)

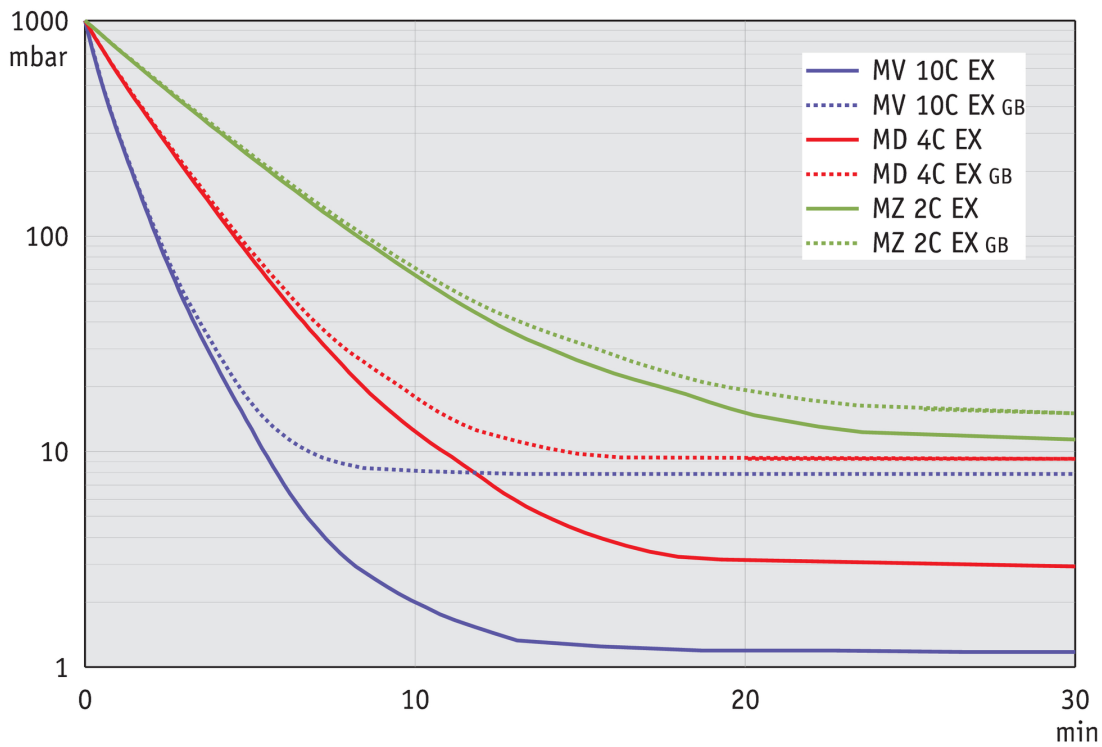

Dimension sheet

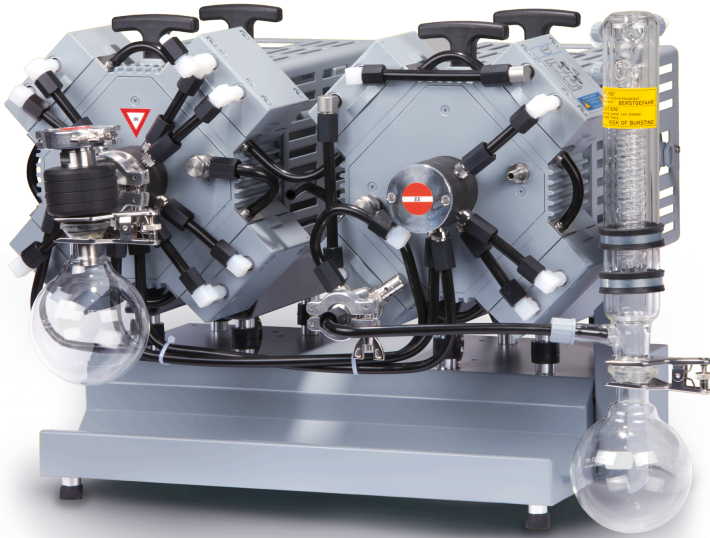

IN - Kleinflansch DN 25 /  
small flange DN 25

EX - Schlauchwelle 10 /  
hose nozzle 10

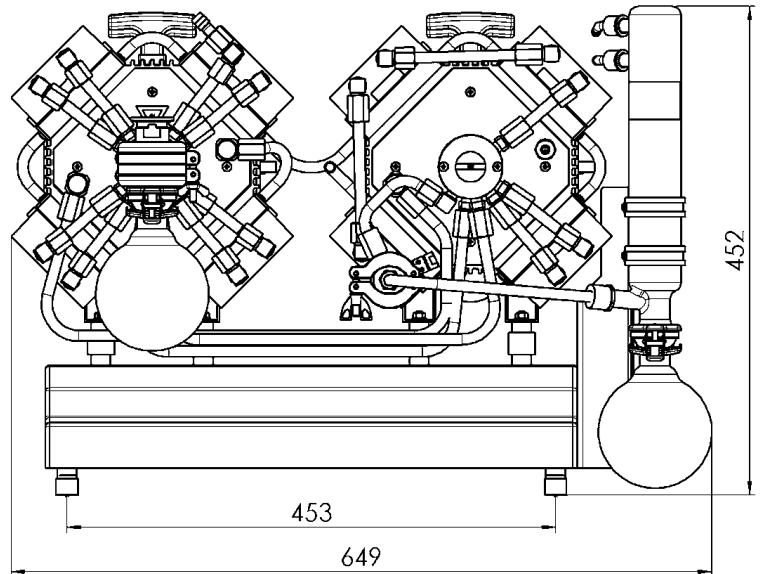
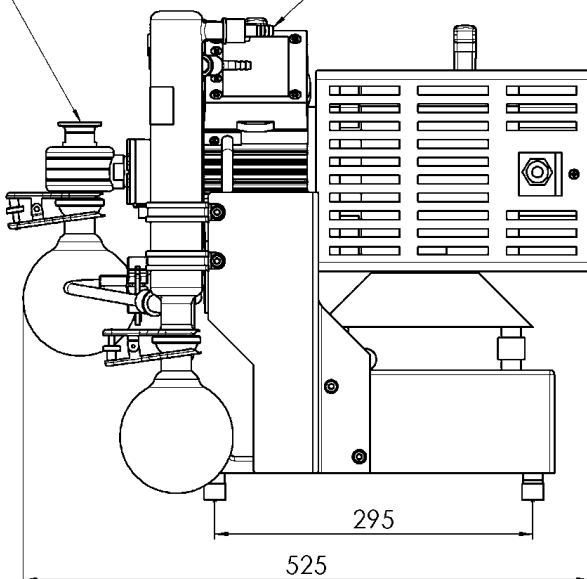

Alle Maße / all dimensions (mm)

VACUUBRAND SSA MV 10C EX AK+EK  
Version 2015/10/21

VACUUBRAND GMBH + CO KG  
P.O. Box 1664  
97877 Wertheim  
T +49 9342 808 5550  
F +49 9342 808 5555

info@vacuubrand.com  
www.vacuubrand.com

**VACUUBRAND®**

VACUUBRAND is part of the Brand group, a manufacturer of high-quality and innovative laboratory equipment and vacuum technology with a global team of approx. 1,000 employees.

With highly motivated and qualified employees, we manufacture the world's most comprehensive product family for vacuum generation, measurement and control for the rough and fine vacuum range in the laboratory.

**All with one goal:**

Enabling our customers to run reliable, safe and efficient processes. This is why we commit ourselves to continuous innovation, first-class performance, and outstanding quality.

Engineering excellence is central to our ability to deliver products and solutions renowned for their quality, durability, and reliability. Innovative technology, high quality materials and extensive testing deliver unmatched performance - engineered and manufactured in Germany.

Together with you, our experts will find the best solution for your application and provide you with first-class service along the way.

BRAND (Shanghai) Trading Co., Ltd.  
Shanghai, China

T +86 21 6422 2318  
info@brand.com.cn  
china.brand.com.cn

BRAND Scientific Equipment Pvt. Ltd.  
Mumbai, India

T +91 22 42957790  
customersupport@brand.co.in  
www.brand.co.in

BRANDTECH® Scientific, Inc.  
Essex, CT. United States of America

T +1 860 767 2562  
info@brandtech.com  
www.brandtech.com