

Chemistry vacuum system ME 4C NT +2AK

[Link to the website](#)

Product description

This chemistry vacuum system provides the advantageous combination of high pumping speed and low ultimate vacuum down to 70 mbar. It is therefore ideal for evacuating and pumping large amounts of gases and vapors. It has a wide range of applications in chemical, biological and pharmaceutical laboratories if condensation of solvent vapors at the outlet is not necessary. Typical applications are vacuum ovens, single and multiple filtrations, as well as concentration of solvents with low boiling points. The separator at the inlet (AK) is made of glass with protective coating and retains particles and liquid droplets. The separator at the outlet collects condensate, avoids condensate backflow towards the pump and makes the pump whisper-quiet.

Performance features

- outstanding chemical resistance and superior vapor tolerance
- high performance even at low vacuum levels
- compact design
- whisper quiet and very low vibration
- separators at inlet and outlet to collect condensates

Ordering data

Product name	Nominal mains voltage mains frequency	Plug type	Articleno.
ME 4C NT +2AK	200-230 V 50-60 Hz 100-115 V 50-60 Hz	IEC plug EN 60320	22614080

Items supplied

Pumping unit completely mounted, ready for use, with manual, with dual voltage motor.

Accessories

- Silencer with hose 5cm DN 8-10mm (20636588)
- VACUU-LAN® module Einstellwinkel 90° (20637873)
- Rubber vacuum tubing DN 8 mm (20686001)

Technical data

Max. pumping speed 50 Hz (mbar)	3.9 m ³ /h
Max. pumping speed 60 Hz (cfm)	2.6 cfm
Ultimate vacuum	70 mbar / 52 torr
Number of heads	2
Number of stages	1
Permissible ambient temperature range (operation)	10 - 40 °C
Permissible ambient temperature range (storage)	-10 - 60 °C
Max. outlet pressure (abs.)	1.1 bar
Inlet connection	Hose nozzle DN 8-10 mm
Outlet connection	Hose nozzle DN 8-10 mm
Rated motor power	0.18 kW
Rated speed 50/60 Hz	1500/1800 min ⁻¹
Protection class IEC 60529	IP 40
Dimensions (L x W x H)	316 mm x 242 mm x 291 mm
Weight	13.6 kg
Noise (sound pressure level) in dBA at 50 Hz or 1500 rpm/62% (VARIO)/1500 rpm (VARIO-SP)/12500 Upm (VACUU·PURE®)	45 dBA
ATEX conformity	II 3/- G Ex h IIC T3 Gc X Internal Atm. only
NRTL certification	Yes

Pumping speed graph at 50 Hz

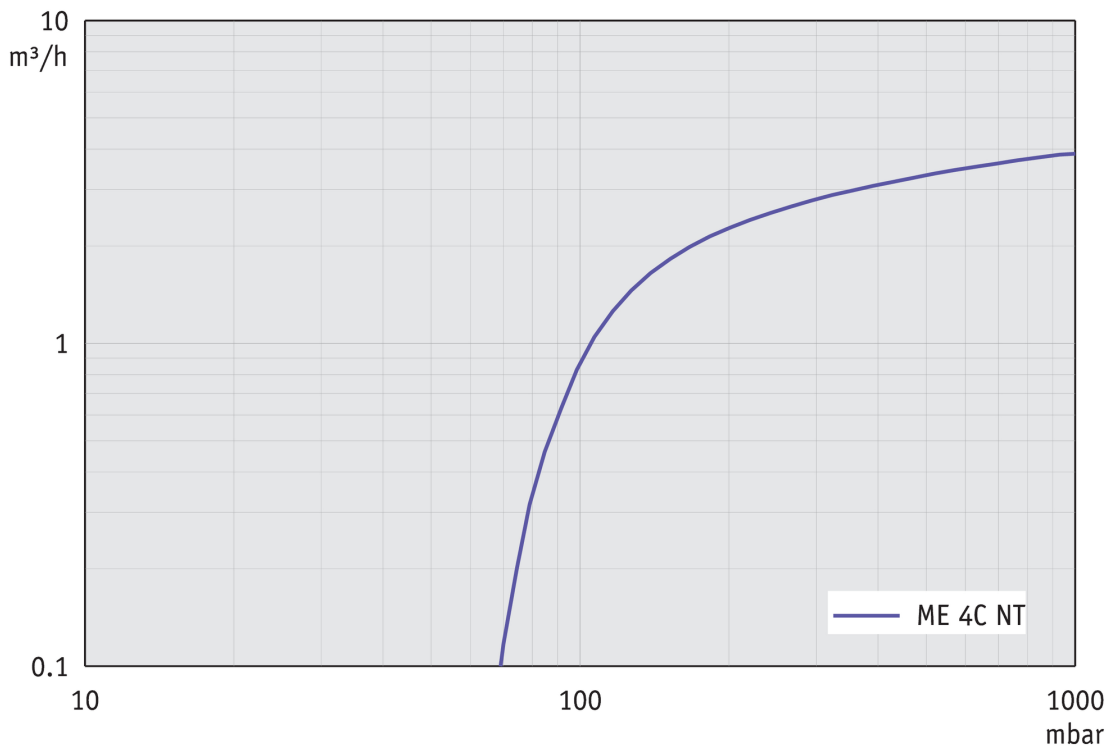

Pump down graph at 50 Hz (10 l volume)

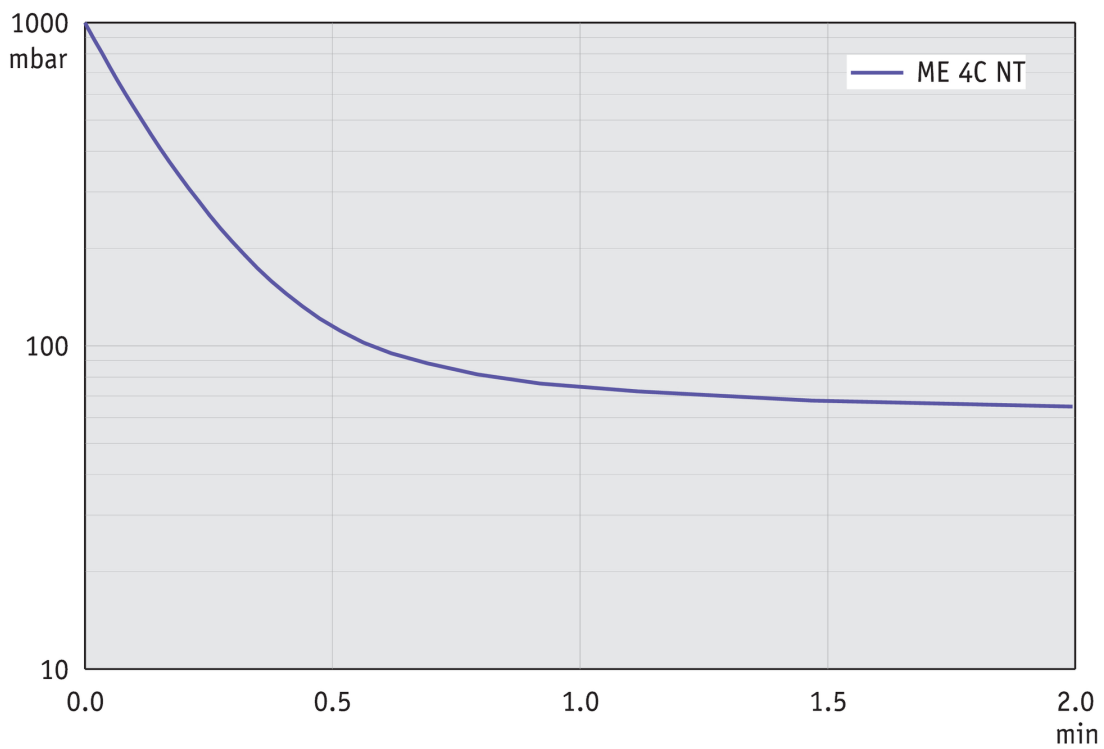

Pumping speed graph at 60 Hz

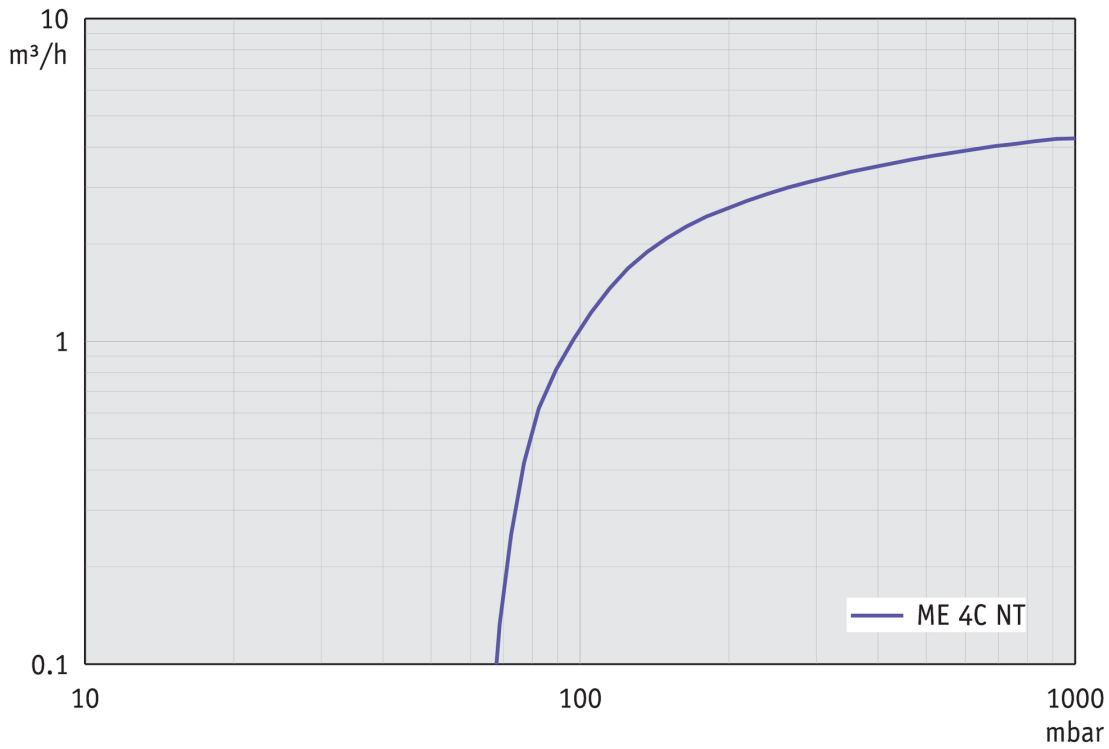

Pump down graph at 60 Hz (10 l volume)

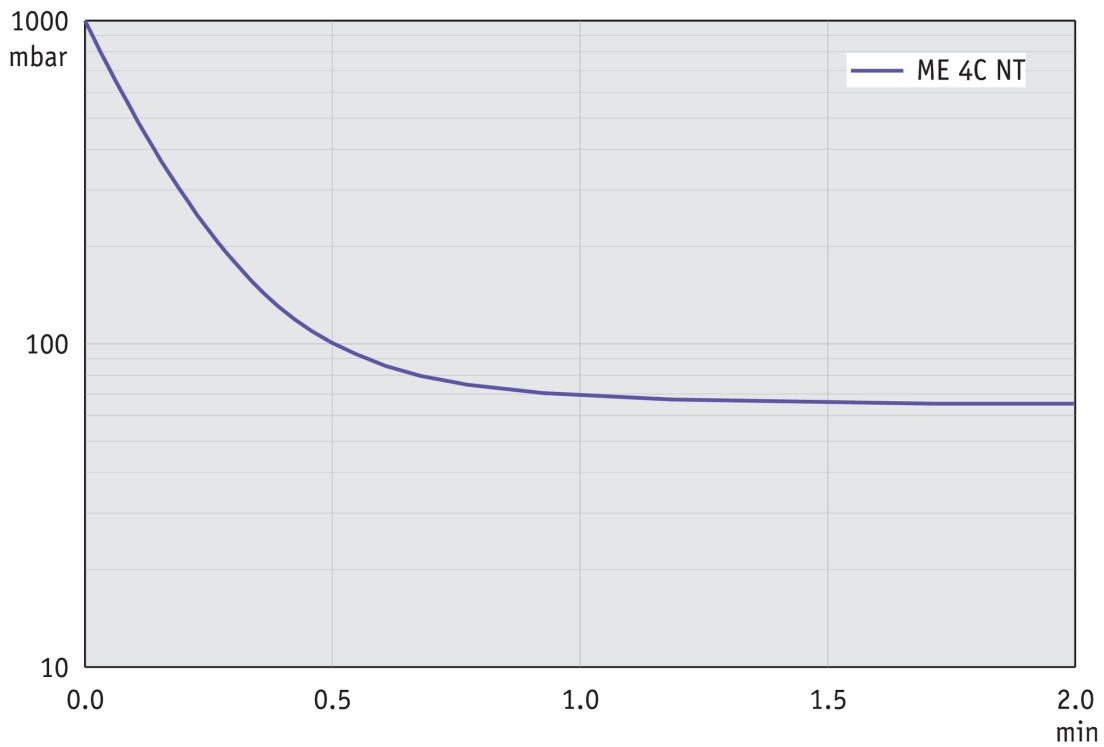

Dimension sheet

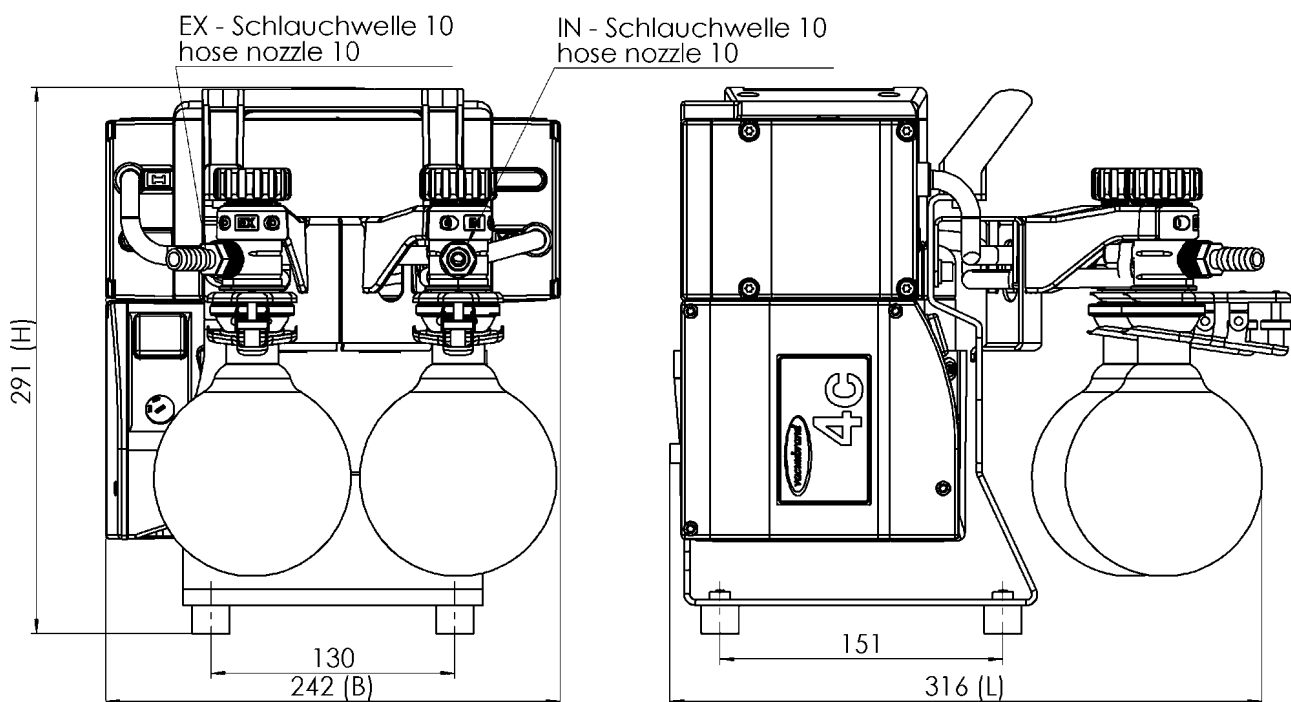

Alle Maße / all dimensions (mm)

VACUUBRAND ME 4C NT 2AK
Version 2011/05/11

VACUUBRAND GMBH + CO KG
P.O. Box 1664
97877 Wertheim
T +49 9342 808 5550
F +49 9342 808 5555

info@vacuubrand.com
www.vacuubrand.com

VACUUBRAND®

VACUUBRAND is part of the Brand group, a manufacturer of high-quality and innovative laboratory equipment and vacuum technology with a global team of approx. 1,000 employees.

With highly motivated and qualified employees, we manufacture the world's most comprehensive product family for vacuum generation, measurement and control for the rough and fine vacuum range in the laboratory.

All with one goal:

Enabling our customers to run reliable, safe and efficient processes. This is why we commit ourselves to continuous innovation, first-class performance, and outstanding quality.

Engineering excellence is central to our ability to deliver products and solutions renowned for their quality, durability, and reliability. Innovative technology, high quality materials and extensive testing deliver unmatched performance - engineered and manufactured in Germany.

Together with you, our experts will find the best solution for your application and provide you with first-class service along the way.

BRAND (Shanghai) Trading Co., Ltd.
Shanghai, China

T +86 21 6422 2318
info@brand.com.cn
china.brand.com.cn

BRAND Scientific Equipment Pvt. Ltd.
Mumbai, India

T +91 22 42957790
customersupport@brand.co.in
www.brand.co.in

BRANDTECH® Scientific, Inc.
Essex, CT. United States of America

T +1 860 767 2562
info@brandtech.com
www.brandtech.com